STATISTICAL OPTICS

- 10.1 STATISTICAL PROPERTIES OF RANDOM LIGHT
 - A. Optical Intensity
 - B. Temporal Coherence and Spectrum
 - C. Spatial Coherence
 - D. Longitudinal Coherence
- 10.2 INTERFERENCE OF PARTIALLY COHERENT LIGHT
 - A. Interference of Two Partially Coherent Waves
 - B. Interference and Temporal Coherence
 - C. Interference and Spatial Coherence
- *10.3 TRANSMISSION OF PARTIALLY COHERENT LIGHT THROUGH OPTICAL SYSTEMS
 - A. Propagation of Partially Coherent Light
 - B. Image Formation with Incoherent Light
 - C. Gain of Spatial Coherence by Propagation
- 10.4 PARTIAL POLARIZATION



Max Born (1882–1970)



Emil Wolf (born 1922)

Principles of Optics, first published in 1959 by Max Born and Emil Wolf, brought attention to the importance of coherence in optics. Emil Wolf is responsible for many advances in the theory of optical coherence.

Statistical optics is the study of the properties of random light. Randomness in light arises because of unpredictable fluctuations of the light source or of the medium through which light propagates. Natural light, e.g., light radiated by a hot object, is random because it is a superposition of emissions from a very large number of atoms radiating independently and at different frequencies and phases. Randomness in light may also be a result of scattering from rough surfaces, diffused glass, or turbulent fluids, which impart random variations to the optical wavefront. The study of the random fluctuations of light is also known as the **theory of optical coherence**.

In the preceding chapters it was assumed that light is deterministic or “coherent.” An example of coherent light is the monochromatic wave $u(\mathbf{r}, t) = \text{Re}\{U(\mathbf{r}) \exp(j2\pi\nu t)\}$, for which the complex amplitude $U(\mathbf{r})$ is a deterministic complex function, e.g., $U(\mathbf{r}) = A \exp(-jkr)/r$ in the case of a spherical wave [Fig. 10.0-1(a)]. The dependence of the wavefunction on time and position is perfectly periodic and predictable. On the other hand, for random light, the dependence of the wavefunction on time and position [Fig. 10.0-1(b)] is not totally predictable and cannot generally be described without resorting to statistical methods.

How can we extract from the fluctuations of a random optical wave some meaningful measures that characterize it and distinguish it from other random waves? Examine, for instance, the three random optical waves whose wavefunctions at some position vary with time as in Fig. 10.0-2. It is apparent that wave (b) is more “intense” than wave (a) and that the envelope of wave (c) fluctuates “faster” than the envelopes of the other two waves. To translate these casual qualitative observations into quantitative measures, we use the concept of statistical averaging to define a number of nonrandom measures. Because the random function $u(\mathbf{r}, t)$ satisfies certain laws (the wave equation and boundary conditions) its statistical averages must also satisfy certain laws. The theory of optical coherence deals with the definitions of these statistical averages, with

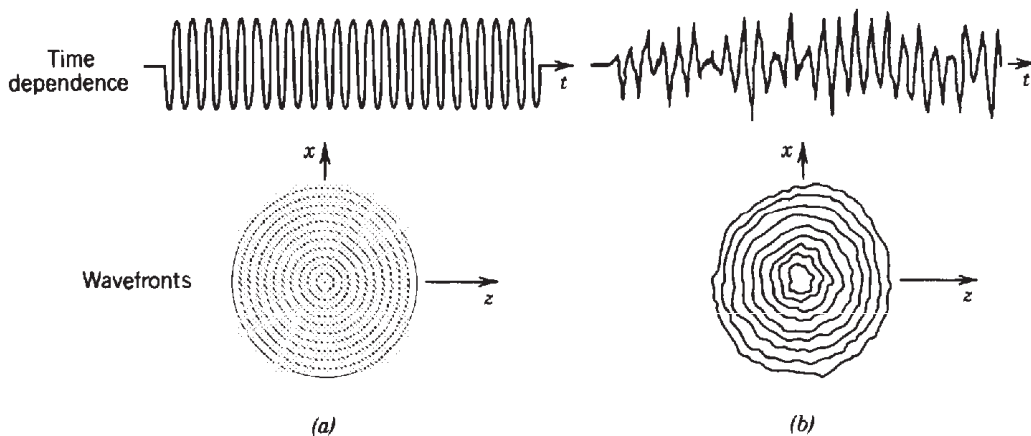

Figure 10.0-1 Time dependence and wavefronts of (a) a monochromatic spherical wave, which is an example of coherent light; (b) random light.

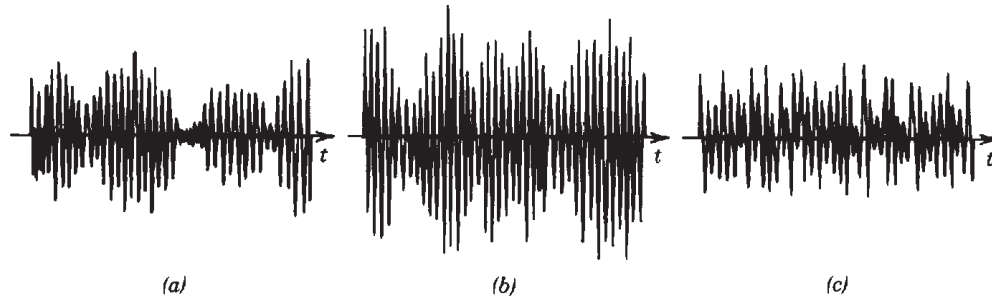

Figure 10.0-2 Time dependence of the wavefunctions of three random waves.

the laws that govern them, and with measures by which light is classified as **coherent**, **incoherent**, or, in general, **partially coherent**.

Familiarity with the theory of random fields (random functions of many variables—space and time) is necessary for a full understanding of the theory of optical coherence. However, the ideas presented in this chapter are limited in scope, so that knowledge of the concept of statistical averaging is sufficient.

In Sec. 10.1 we define two statistical averages used to describe random light: the optical intensity and the mutual coherence function. Temporal and spatial coherence are delineated, and the connection between temporal coherence and monochromaticity is established. The examples of partially coherent light provided in Sec. 10.1 demonstrate that spatially coherent light need not be temporally coherent, and that monochromatic light need not be spatially coherent. One of the basic manifestations of the coherence of light is its ability to produce visible interference fringes. Section 10.2 is devoted to the laws of interference of random light. The transmission of partially coherent light in free space and through different optical systems, including image-formation systems, is the subject of Sec. 10.3. A brief introduction to the theory of polarization of random light (partial polarization) is provided in Sec. 10.4.

10.1 STATISTICAL PROPERTIES OF RANDOM LIGHT

An arbitrary optical wave is described by a wavefunction $u(\mathbf{r}, t) = \text{Re}\{U(\mathbf{r}, t)\}$, where $U(\mathbf{r}, t)$ is the complex wavefunction. For example, $U(\mathbf{r}, t)$ may take the form $U(\mathbf{r})\exp(j2\pi\nu t)$ for monochromatic light, or it may be a sum of many similar functions of different ν for polychromatic light (see Sec. 2.6A for a discussion of the complex wavefunction). For random light, both functions, $u(\mathbf{r}, t)$ and $U(\mathbf{r}, t)$, are random and are characterized by a number of statistical averages introduced in this section.

A. Optical Intensity

The intensity $I(\mathbf{r}, t)$ of coherent (deterministic) light is the absolute square of the complex wavefunction $U(\mathbf{r}, t)$,

$$I(\mathbf{r}, t) = |U(\mathbf{r}, t)|^2. \quad (10.1-1)$$

(see Sec. 2.2A, and 2.6A). For monochromatic deterministic light the intensity is independent of time, but for pulsed light it is time varying.

For random light, $U(\mathbf{r}, t)$ is a random function of time and position. The intensity $|U(\mathbf{r}, t)|^2$ is therefore also random. The **average intensity** is then defined as

$$I(\mathbf{r}, t) = \langle |U(\mathbf{r}, t)|^2 \rangle. \quad (10.1-2)$$

Average Intensity

where the symbol $\langle \cdot \rangle$ now denotes an ensemble average over many realizations of the random function. This means that the wave is produced repeatedly under the same conditions, with each trial yielding a different wavefunction, and the average intensity at each time and position is determined. When there is no ambiguity we shall simply call $I(\mathbf{r}, t)$ the *intensity* of light (with the word “average” implied). The quantity $|U(\mathbf{r}, t)|^2$ is called the **random** or **instantaneous intensity**. For deterministic light, the averaging operation is unnecessary since all trials produce the same wavefunction, so that (10.1-2) is equivalent to (10.1-1).

The average intensity may be time independent or may be a function of time, as illustrated in Figs. 10.1-1(a) and (b), respectively. The former case applies when the optical wave is statistically **stationary**; that is, its statistical averages are invariant to time. The instantaneous intensity $|U(\mathbf{r}, t)|^2$ fluctuates randomly with time, but its average is constant. We will denote it, in this case, by $I(\mathbf{r})$. Stationarity does not

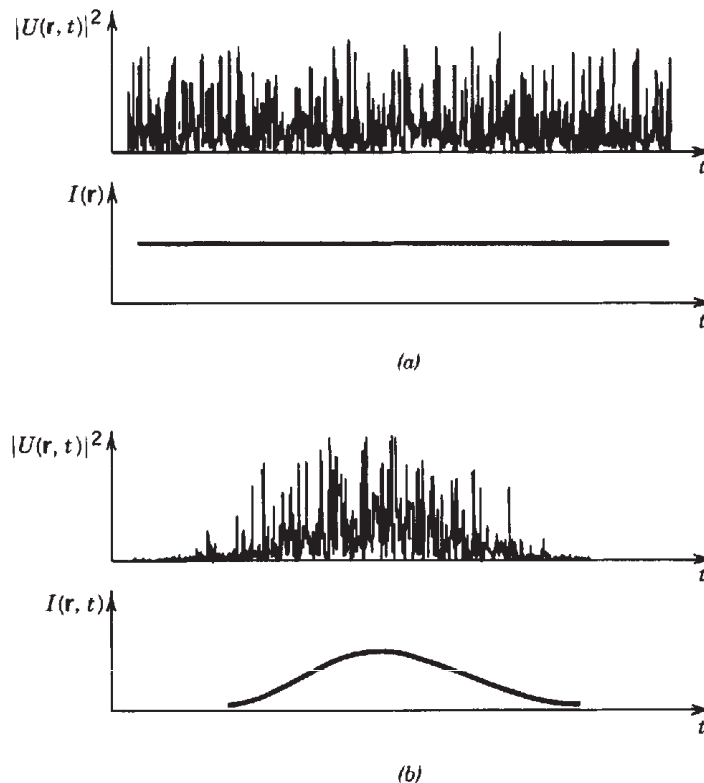

Figure 10.1-1 (a) A statistically stationary wave has an average intensity that does not vary with time. (b) A statistically nonstationary wave has a time-varying intensity. These plots represent, e.g., the intensity of light from an incandescent lamp driven by a constant electric current in (a) and a pulse of electric current in (b).

necessarily mean constancy. It means constancy of the average properties. An example of stationary random light is that from an ordinary incandescent lamp heated by a constant electric current. The average intensity $I(\mathbf{r})$ is a function of distance from the lamp, but it does not vary with time. However, the random intensity $|U(\mathbf{r}, t)|^2$ fluctuates with both position and time, as illustrated in Fig. 10.1-1(a).

When the light is stationary, the statistical averaging operation in (10.1-2) can usually be determined by time averaging over a long time duration (instead of averaging over many realizations of the wave), whereupon

$$I(\mathbf{r}) = \lim_{T \rightarrow \infty} \frac{1}{2T} \int_{-T}^T |U(\mathbf{r}, t)|^2 dt. \quad (10.1-3)$$

B. Temporal Coherence and Spectrum

Consider the fluctuations of *stationary* light at a fixed position \mathbf{r} as a function of time. The stationary random function $U(\mathbf{r}, t)$ has a constant intensity $I(\mathbf{r}) = \langle |U(\mathbf{r}, t)|^2 \rangle$. For brevity, we drop the \mathbf{r} dependence (since \mathbf{r} is fixed), so that $U(\mathbf{r}, t) = U(t)$ and $I(\mathbf{r}) = I$.

The random fluctuations of $U(t)$ are characterized by a time scale representing the “memory” of the random function. Fluctuations at points separated by a time interval longer than the memory time are independent, so that the process “forgets” itself. The function appears to be smooth within its memory time, but “rough” and “erratic” when examined over longer time scales (see Fig. 10.0-2). A quantitative measure of this temporal behavior is established by defining a statistical *average* known as the autocorrelation function. This function describes the extent to which the wavefunction fluctuates in unison at two instants of time separated by a given time delay, so that it establishes the time scale of the process that underlies the generation of the wavefunction.

Temporal Coherence Function

The autocorrelation function of a stationary complex random function $U(t)$ is the average of the product of $U^*(t)$ and $U(t + \tau)$ as a function of the time delay τ

$$G(\tau) = \langle U^*(t)U(t + \tau) \rangle \quad (10.1-4)$$

Temporal Coherence
Function

or

$$G(\tau) = \lim_{T \rightarrow \infty} \frac{1}{2T} \int_{-T}^T U^*(t)U(t + \tau) dt$$

(see Sec. A.1 in Appendix A).

To understand the significance of the definition in (10.1-4), consider the case in which the average value of the complex wavefunction $\langle U(t) \rangle = 0$. This is applicable when the phase of the phasor $U(t)$ is equally likely to have any value between 0 and 2π , as illustrated in Fig. 10.1-2. The phase of the product $U^*(t)U(t + \tau)$ is the angle between phasors $U(t)$ and $U(t + \tau)$. If $U(t)$ and $U(t + \tau)$ are uncorrelated, the angle between their phasors varies randomly between 0 and 2π . The phasor $U^*(t)U(t + \tau)$ then has a totally uncertain angle, so that it is equally likely to take any direction,

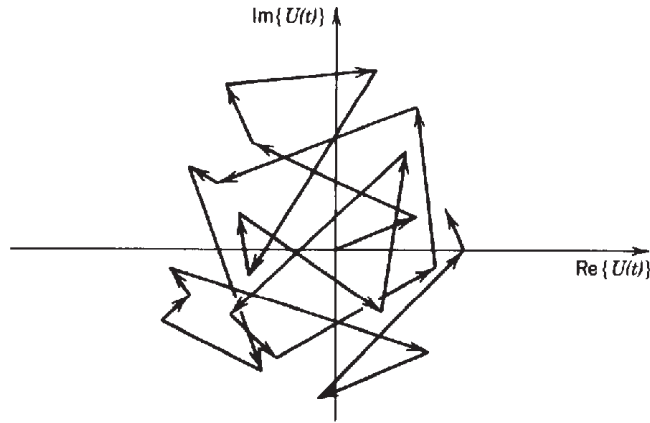

Figure 10.1-2 Variation of the phasor $U(t)$ with time when its argument is uniformly distributed between 0 and 2π . The average values of its real and imaginary parts are zero, so that $\langle U(t) \rangle = 0$.

making its average, the autocorrelation function $G(\tau)$, vanish. On the other hand if, for a given τ , $U(t)$ and $U(t + \tau)$ are correlated, their phasors will maintain some relationship. Their fluctuations are then linked together so that the product phasor $U^*(t)U(t + \tau)$ has a preferred direction and its average $G(\tau)$ will not vanish.

In the language of optical coherence theory, the autocorrelation function $G(\tau)$ is known as the **temporal coherence function**. It is easy to show that $G(\tau)$ is a function with Hermitian symmetry, $G(-\tau) = G^*(\tau)$, and that the intensity I , defined by (10.1-2), is equal to $G(\tau)$ when $\tau = 0$,

$$I = G(0). \quad (10.1-5)$$

Degree of Temporal Coherence

The temporal coherence function $G(\tau)$ carries information about both the intensity $I = G(0)$ and the degree of correlation (coherence) of stationary light. A measure of coherence that is insensitive to the intensity is provided by the normalized autocorrelation function,

$$g(\tau) = \frac{G(\tau)}{G(0)} = \frac{\langle U^*(t)U(t + \tau) \rangle}{\langle U^*(t)U(t) \rangle}, \quad (10.1-6)$$

Complex Degree
of Temporal
Coherence

which is called the **complex degree of temporal coherence**. Its absolute value cannot exceed unity,

$$0 \leq |g(\tau)| \leq 1. \quad (10.1-7)$$

The value of $|g(\tau)|$ is a measure of the degree of correlation between $U(t)$ and $U(t + \tau)$. When the light is deterministic and monochromatic, i.e., $U(t) = A \exp(j2\pi\nu_0 t)$, where A is a constant, (10.1-6) gives

$$g(\tau) = \exp(j2\pi\nu_0\tau), \quad (10.1-8)$$

so that $|g(\tau)| = 1$ for all τ . The variables $U(t)$ and $U(t + \tau)$ are then completely correlated for all time delays τ . Usually, $|g(\tau)|$ drops from its largest value $|g(0)| = 1$ as τ increases and the fluctuations become uncorrelated for sufficiently large time delay τ .

Coherence Time

If $|g(\tau)|$ decreases monotonically with time delay, the value τ_c at which it drops to a prescribed value ($\frac{1}{2}$ or $1/e$, for example) serves as a measure of the memory time of the fluctuations known as the **coherence time** (see Fig. 10.1-3). For $\tau < \tau_c$ the fluctuations are “strongly” correlated whereas for $\tau > \tau_c$ they are “weakly” correlated. In general, τ_c is the width of the function $|g(\tau)|$. Although the definition of the width of a function is rather arbitrary (see Sec. A.2 of Appendix A), the power-equivalent width

$$\tau_c = \int_{-\infty}^{\infty} |g(\tau)|^2 d\tau$$

(10.1-9)
Coherence Time

is commonly used as the definition of coherence time [see (A.2-8) and note that $g(0) = 1$]. The coherence time of monochromatic light is infinite since $|g(\tau)| = 1$ everywhere.

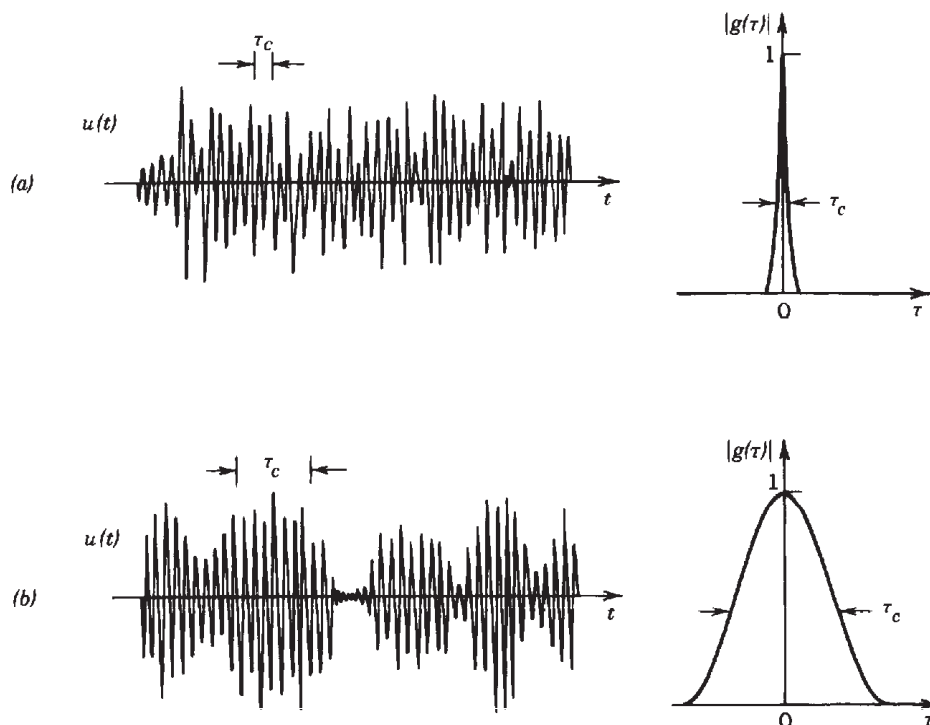

Figure 10.1-3 Illustrative examples of the wavefunction, the magnitude of the complex degree of temporal coherence $|g(\tau)|$, and the coherence time τ_c for an optical field with (a) short coherence time and (b) long coherence time. The amplitude and phase of the wavefunction vary randomly with time constants approximately equal to the coherence time. In both cases the coherence time τ_c is greater than the duration of an optical cycle. Within the coherence time, the wave is rather predictable and can be approximated as a sinusoid. However, given the amplitude and phase of the wave at a particular time, one cannot predict the amplitude and phase at times beyond the coherence time.

EXERCISE 10.1-1

Coherence Time. Verify that the following expressions for the complex degree of temporal coherence are consistent with the definition of τ_c given in (10.1-9):

$$g(\tau) = \begin{cases} \exp\left(-\frac{|\tau|}{\tau_c}\right) & \text{(exponential)} \\ \exp\left(-\frac{\pi\tau^2}{2\tau_c^2}\right) & \text{(Gaussian)}. \end{cases}$$

By what factor does $|g(\tau)|$ drop as τ increases from 0 to τ_c in each case?

Light for which the coherence time τ_c is much longer than the differences of the time delays encountered in the optical system of interest is effectively completely coherent. Thus light is effectively coherent if the distance $c\tau_c$ is much greater than all optical path-length differences encountered. The distance

$$\boxed{l_c = c\tau_c} \qquad (10.1-10)$$

Coherence Length

is known as the **coherence length**.

Power Spectral Density

To determine the *average* spectrum of random light, we carry out a Fourier decomposition of the random function $U(t)$. The amplitude of the component with frequency ν is the Fourier transform (see Appendix A)

$$V(\nu) = \int_{-\infty}^{\infty} U(t) \exp(-j2\pi\nu t) dt.$$

The average energy per unit area of those components with frequencies in the interval between ν and $\nu + d\nu$ is $\langle |V(\nu)|^2 \rangle d\nu$, so that $\langle |V(\nu)|^2 \rangle$ represents the energy spectral density of the light (energy per unit area per unit frequency). Note that the complex wavefunction $U(t)$ has been defined so that $V(\nu) = 0$ for negative ν (see Sec. 2.6A).

Since a truly stationary function $U(t)$ is eternal and carries infinite energy, we consider instead the *power* spectral density. We first determine the energy spectral density of the function $U(t)$ observed over a window of time width T by finding the truncated Fourier transform

$$V_T(\nu) = \int_{-T/2}^{T/2} U(t) \exp(-j2\pi\nu t) dt \qquad (10.1-11)$$

and then determine the energy spectral density $\langle |V_T(\nu)|^2 \rangle$. The power spectral density is the energy per unit time $(1/T)\langle |V_T(\nu)|^2 \rangle$. We can now extend the time window to infinity by taking the limit $T \rightarrow \infty$. The result

$$S(\nu) = \lim_{T \rightarrow \infty} \frac{1}{T} \langle |V_T(\nu)|^2 \rangle, \quad (10.1-12)$$

is called the **power spectral density**. It is nonzero only for positive frequencies. Because $U(t)$ was defined such that $|U(t)|^2$ represents power per unit area, or intensity (W/cm^2), $S(\nu) d\nu$ represents the average power per unit area carried by frequencies between ν and $\nu + d\nu$, so that $S(\nu)$ actually represents the intensity spectral density ($\text{W}/\text{cm}^2\text{-Hz}$). It is often referred to simply as the **spectral density** or the **spectrum**. The total average intensity is the integral

$$I = \int_0^\infty S(\nu) d\nu. \quad (10.1-13)$$

The autocorrelation function $G(\tau)$, defined by (10.1-4), and the spectral density $S(\nu)$ defined by (10.1-12) can be shown to form a Fourier transform pair (see Problem 10.1-2),

$$S(\nu) = \int_{-\infty}^{\infty} G(\tau) \exp(-j2\pi\nu\tau) d\tau. \quad (10.1-14)$$

Power Spectral Density

This relation is known as the **Wiener-Khinchin theorem**.

An optical wave representing a color image, such as the illustration in Fig. 10.1-4, has a spectrum that varies with position \mathbf{r} ; each spectral profile shown corresponds to a perceived color.

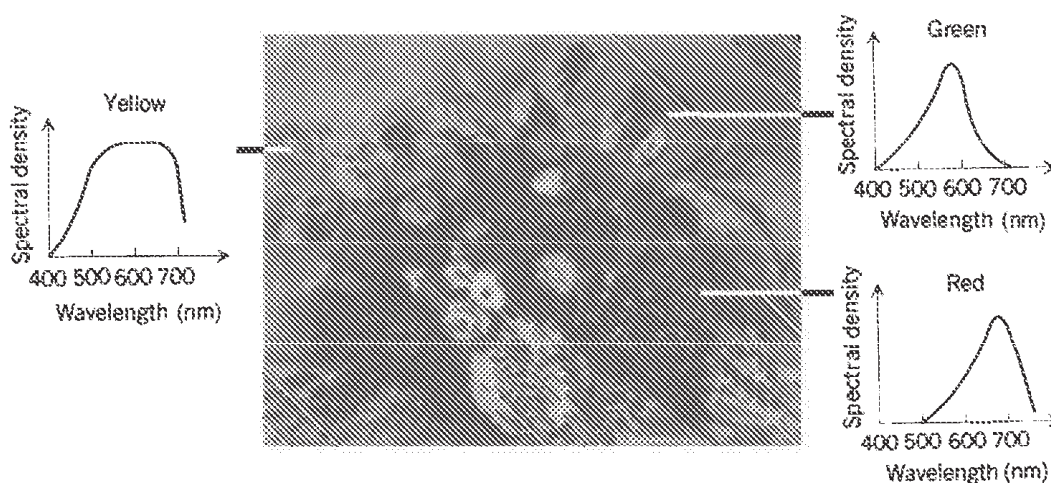

Figure 10.1-4 Variation of the spectral density as a function of wavelength at three positions in a color image (Bouquet of Flowers in a White Vase, Henri Matisse, Pushkin Museum of Fine Arts, Moscow).

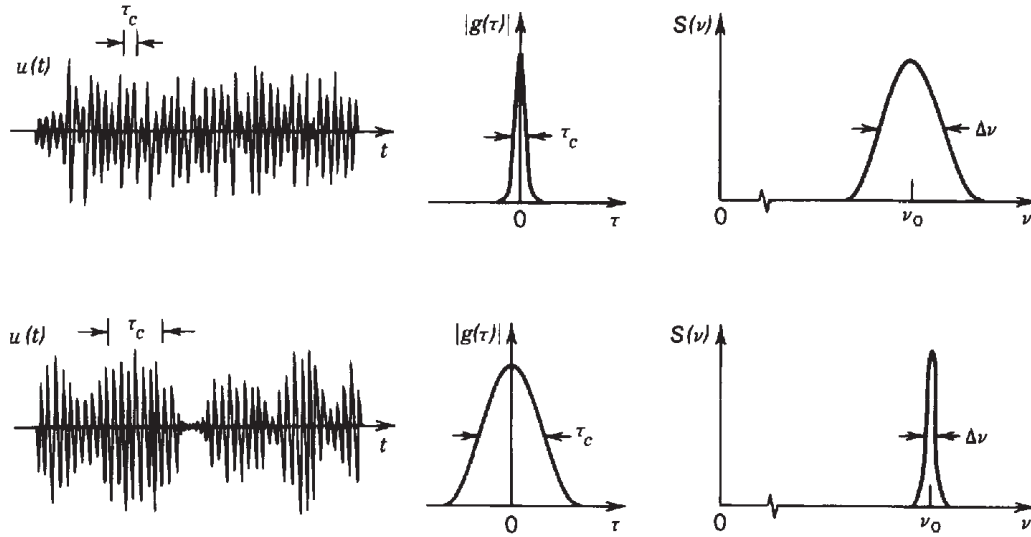

Figure 10.1-5 Two random waves, the magnitudes of their complex degree of temporal coherence, and their spectral densities.

Spectral Width

The spectrum of light is often confined to a narrow band centered about a central frequency ν_0 . The **spectral width**, or **linewidth**, of light is the width $\Delta\nu$ of the spectral density $S(\nu)$. Because of the Fourier-transform relation between $S(\nu)$ and $G(\tau)$, their widths are inversely related. A light source of broad spectrum has a short coherence time, whereas a light source with narrow linewidth has a long coherence time, as illustrated in Fig. 10.1-5. In the limiting case of monochromatic light, $G(\tau) = I \exp(j2\pi\nu_0\tau)$, so that the corresponding intensity spectral density $S(\nu) = I\delta(\nu - \nu_0)$ contains only a single frequency component, ν_0 . Thus $\tau_c = \infty$ and $\Delta\nu = 0$. The coherence time of a light source can be increased by using an optical filter to reduce its spectral width. The resultant gain of coherence comes at the expense of losing light energy.

There are several definitions for the spectral width. The most common is the full width of the function $S(\nu)$ at half its maximum value (FWHM). The relation between the coherence time and the spectral width depends on the spectral profile, as indicated in Table 10.1-1 (see also Appendix A, Sec. A.2).

TABLE 10.1-1 Relation Between Spectral Width and Coherence Time

Spectral Density	Spectral Width $\Delta\nu_{\text{FWHM}}$
Rectangular	$\frac{1}{\tau_c}$
Lorentzian	$\frac{1}{\pi\tau_c} \approx \frac{0.32}{\tau_c}$
Gaussian	$\frac{(2 \ln 2/\pi)^{1/2}}{\tau_c} \approx \frac{0.66}{\tau_c}$

Another convenient definition of the spectral width is

$$\Delta\nu_c = \frac{\left(\int_0^\infty S(\nu) d\nu\right)^2}{\int_0^\infty S^2(\nu) d\nu}. \quad (10.1-15)$$

By this definition it can be shown that

$$\Delta\nu_c = \frac{1}{\tau_c}, \quad (10.1-16)$$

Spectral Width

regardless of the spectral profile (see Exercise 10.1-2). If $S(\nu)$ is a rectangular function extending over a frequency interval from $\nu_0 - B/2$ to $\nu_0 + B/2$, for example, then (10.1-15) yields $\Delta\nu_c = B$. The two definitions of bandwidth, $\Delta\nu_c$ and $\Delta\nu_{\text{FWHM}} \equiv \Delta\nu$, differ by a factor that ranges from $1/\pi \approx 0.32$ to 1 for the profiles listed in Table 10.1-1.

EXERCISE 10.1-2

Relation Between Spectral Width and Coherence Time. Show that the coherence time τ_c defined by (10.1-9) is related to the spectral width $\Delta\nu_c$ defined in (10.1-15) by the simple inverse relation $\tau_c = 1/\Delta\nu_c$. *Hint:* Use the definitions of $\Delta\nu_c$ and τ_c , the Fourier transform relation between $S(\nu)$ and $G(\tau)$, and Parseval's theorem [see (A.1-7) in Appendix A].

Representative spectral bandwidths for different light sources, and their associated coherence times and coherence lengths $l_c = c\tau_c$, are provided in Table 10.1-2.

TABLE 10.1-2 Spectral Widths of a Number of Light Sources Together with Their Coherence Times and Coherence Lengths in Free Space

Source	$\Delta\nu_c$ (Hz)	$\tau_c = 1/\Delta\nu_c$	$l_c = c\tau_c$
Filtered sunlight ($\lambda_o = 0.4\text{--}0.8 \mu\text{m}$)	3.75×10^{14}	2.67 fs	800 nm
Light-emitting diode ($\lambda_o = 1 \mu\text{m}$, $\Delta\lambda_o = 50 \text{ nm}$)	1.5×10^{13}	67 fs	20 μm
Low-pressure sodium lamp	5×10^{11}	2 ps	600 μm
Multimode He-Ne laser ($\lambda_o = 633 \text{ nm}$)	1.5×10^9	0.67 ns	20 cm
Single-mode He-Ne laser ($\lambda_o = 633 \text{ nm}$)	1×10^6	1 μs	300 m

EXAMPLE 10.1-1. A Wave Comprising a Random Sequence of Wavepackets.

Light emitted from an incoherent source may be modeled as a sequence of wavepackets emitted at random times (Fig. 10.1-6). Each wavepacket has a random phase since it is emitted by a different atom. The wavepackets may be sinusoidal with an exponentially decaying envelope, for example, so that a wavepacket emitted at $t = 0$ has a complex wavefunction (at a given position)

$$U_p(t) = \begin{cases} A_p \exp\left(-\frac{t}{\tau_c}\right) \exp(j2\pi\nu_0 t), & t \geq 0 \\ 0, & t < 0. \end{cases}$$

The emission times are totally random, and the random independent phases of the different emissions are included in A_p . The statistical properties of the total field may be determined by performing the necessary averaging operations using the rules of mathematical statistics. The result yields a complex degree of coherence given by $g(\tau) = \exp(-|\tau|/\tau_c) \exp(j2\pi\nu_0\tau)$ whose magnitude is a double-sided exponential function. The corresponding power spectral density is Lorentzian, $S(\nu) = (\Delta\nu/2\pi)/[(\nu - \nu_0)^2 + (\Delta\nu/2)^2]$, where $\Delta\nu = 1/\pi\tau_c$ (see Table A.1-1 in Appendix A). The coherence time τ_c in this case is exactly the width of a wavepacket. The statement that this light is correlated within the coherence time therefore means that it is correlated within the duration of an individual wavepacket.

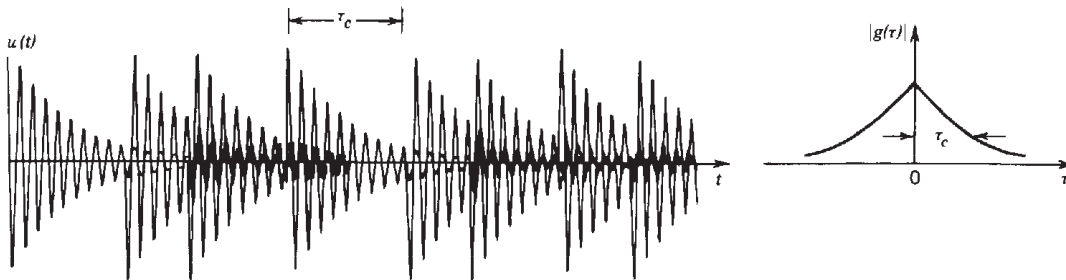

Figure 10.1-6 Light comprised of wavepackets emitted at random times has a coherence time equal to the duration of a wavepacket.

C. Spatial Coherence

Mutual Coherence Function

An important descriptor of the spatial and temporal fluctuations of the random function $U(\mathbf{r}, t)$ is the cross-correlation function of $U(\mathbf{r}_1, t)$ and $U(\mathbf{r}_2, t)$ at pairs of positions \mathbf{r}_1 and \mathbf{r}_2 ,

$$G(\mathbf{r}_1, \mathbf{r}_2, \tau) = \langle U^*(\mathbf{r}_1, t) U(\mathbf{r}_2, t + \tau) \rangle. \quad (10.1-17)$$

Mutual Coherence
Function

This function of the time delay τ is known as the **mutual coherence function**. Its

normalized form,

$$g(\mathbf{r}_1, \mathbf{r}_2, \tau) = \frac{G(\mathbf{r}_1, \mathbf{r}_2, \tau)}{[I(\mathbf{r}_1)I(\mathbf{r}_2)]^{1/2}}, \quad (10.1-18)$$

Complex Degree
of Coherence

is called the **complex degree of coherence**. When the two points coincide so that $\mathbf{r}_1 = \mathbf{r}_2 = \mathbf{r}$, (10.1-17) and (10.1-18) reproduce the temporal coherence function and the complex degree of temporal coherence defined in (10.1-4) and (10.1-6) at the position \mathbf{r} . Ultimately, when $\tau = 0$, the intensity is $I(\mathbf{r}) = G(\mathbf{r}, \mathbf{r}, 0)$ at the position \mathbf{r} .

The complex degree of coherence $g(\mathbf{r}_1, \mathbf{r}_2, \tau)$ is the cross-correlation coefficient of the random variables $U^*(\mathbf{r}_1, t)$ and $U(\mathbf{r}_2, t + \tau)$. Its absolute value is bounded between zero and unity,

$$0 \leq |g(\mathbf{r}_1, \mathbf{r}_2, \tau)| \leq 1. \quad (10.1-19)$$

It is therefore considered a measure of the degree of correlation between the fluctuations at \mathbf{r}_1 and those at \mathbf{r}_2 at a time τ later.

When the two phasors $U(\mathbf{r}_1, t)$ and $U(\mathbf{r}_2, t)$ fluctuate independently and their phases are totally random (each having equally probable phase between 0 and 2π), $|g(\mathbf{r}_1, \mathbf{r}_2, \tau)| = 0$ since the average of the product $U^*(\mathbf{r}_1, t)U(\mathbf{r}_2, t + \tau)$ vanishes. The light fluctuations at the two points are then uncorrelated. The other limit, $|g(\mathbf{r}_1, \mathbf{r}_2, \tau)| = 1$, applies when the light fluctuations at \mathbf{r}_1 , and at \mathbf{r}_2 a time τ later, are fully correlated. Note that $|g(\mathbf{r}_1, \mathbf{r}_2, 0)|$ is not necessarily unity, however by definition $|g(\mathbf{r}, \mathbf{r}, 0)| = 1$.

The dependence of $g(\mathbf{r}_1, \mathbf{r}_2, \tau)$ on time delay and on the positions characterizes the temporal and spatial coherence of light. Two examples of the dependence of $|g(\mathbf{r}_1, \mathbf{r}_2, \tau)|$ on the distance $|\mathbf{r}_1 - \mathbf{r}_2|$ and the time delay τ are illustrated in Fig. 10.1-7.

The temporal and spatial fluctuations of light are intimately related since light propagates in waves and the complex wavefunction $U(\mathbf{r}, t)$ must satisfy the wave

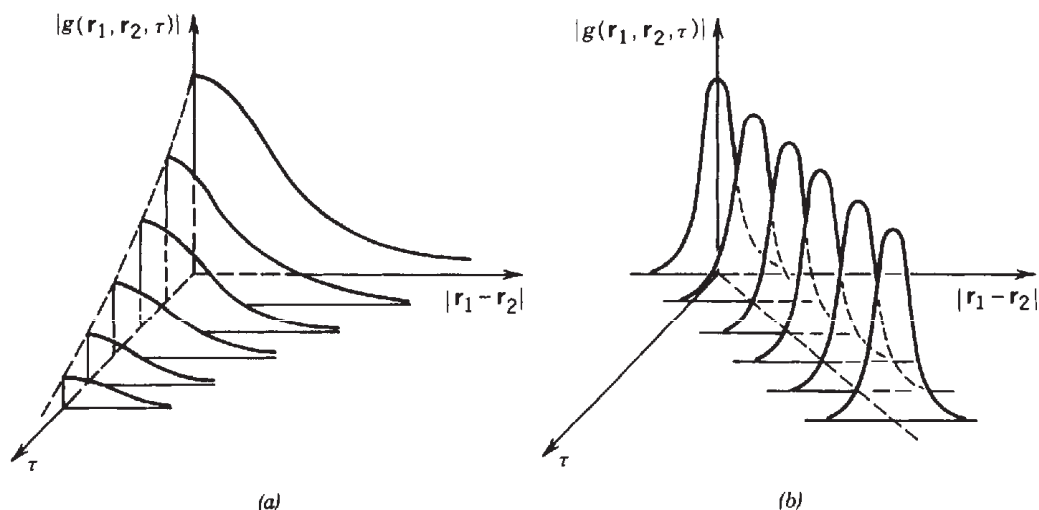

Figure 10.1-7 Two examples of $|g(\mathbf{r}_1, \mathbf{r}_2, \tau)|$ as a function of the separation $|\mathbf{r}_1 - \mathbf{r}_2|$ and the time delay τ . In (a) the maximum correlation for a given $|\mathbf{r}_1 - \mathbf{r}_2|$ occurs at $\tau = 0$. In (b) the maximum correlation occurs at $|\mathbf{r}_1 - \mathbf{r}_2| = c\tau$.

equation. This imposes certain conditions on the mutual coherence function (see Exercise 10.1-3). To illustrate this point, consider, for example, a plane wave of random light traveling in the z direction in a homogeneous and nondispersive medium with velocity c . Fluctuations at the points $\mathbf{r}_1 = (0, 0, z_1)$ and $\mathbf{r}_2 = (0, 0, z_2)$ are completely correlated when the time delay is $\tau = \tau_0 \equiv |z_2 - z_1|/c$, so that $|g(\mathbf{r}_1, \mathbf{r}_2, \tau_0)| = 1$. As a function of τ , $|g(\mathbf{r}_1, \mathbf{r}_2, \tau)|$ has a peak at $\tau = \tau_0$, as illustrated in Fig. 10.1-7(b). This example will be discussed again in Sec. 10.1D.

EXERCISE 10.1-3

Differential Equations Governing the Mutual Coherence Function. In free space, $U(\mathbf{r}, t)$ must satisfy the wave equation, $\nabla^2 U - (1/c^2)\partial^2 U/\partial t^2 = 0$. Use the definition (10.1-17) to show that the mutual coherence function $G(\mathbf{r}_1, \mathbf{r}_2, \tau)$ satisfies the two partial differential equations

$$\nabla_1^2 G - \frac{1}{c^2} \frac{\partial^2 G}{\partial \tau^2} = 0 \quad (10.1-20a)$$

$$\nabla_2^2 G - \frac{1}{c^2} \frac{\partial^2 G}{\partial \tau^2} = 0, \quad (10.1-20b)$$

where ∇_1^2 and ∇_2^2 are the Laplacian operators with respect to \mathbf{r}_1 and \mathbf{r}_2 , respectively.

Mutual Intensity

The spatial correlation of light may be assessed by examining the dependence of the mutual coherence function on position for a fixed time delay τ . In many situations the point $\tau = 0$ is the most appropriate, as in the example in Fig. 10.1-7(a). However, this need not always be the case, as in the example in Fig. 10.1-7(b). The mutual coherence function at $\tau = 0$,

$$G(\mathbf{r}_1, \mathbf{r}_2, 0) = \langle U^*(\mathbf{r}_1, t)U(\mathbf{r}_2, t) \rangle,$$

is known as the **mutual intensity** and is denoted by $G(\mathbf{r}_1, \mathbf{r}_2)$ for simplicity. The diagonal values of the mutual intensity ($\mathbf{r}_1 = \mathbf{r}_2 = \mathbf{r}$) provide the intensity $I(\mathbf{r}) = G(\mathbf{r}, \mathbf{r})$.

When the optical path differences encountered in an optical system are much shorter than the coherence length $l_c = c\tau_c$, the light may be considered to effectively possess complete temporal coherence, so that the mutual coherence function is a harmonic function of time:

$$G(\mathbf{r}_1, \mathbf{r}_2, \tau) = G(\mathbf{r}_1, \mathbf{r}_2) \exp(j2\pi\nu_0\tau), \quad (10.1-21)$$

where ν_0 is the central frequency. In this case the light is said to be **quasi-monochromatic** and the mutual intensity $G(\mathbf{r}_1, \mathbf{r}_2)$ describes the spatial coherence completely.

The complex degree of coherence $g(\mathbf{r}_1, \mathbf{r}_2, 0)$ is similarly denoted by $g(\mathbf{r}_1, \mathbf{r}_2)$. Thus

$$g(\mathbf{r}_1, \mathbf{r}_2) = \frac{G(\mathbf{r}_1, \mathbf{r}_2)}{[I(\mathbf{r}_1)I(\mathbf{r}_2)]^{1/2}} \quad (10.1-22)$$

Normalized
Mutual Intensity

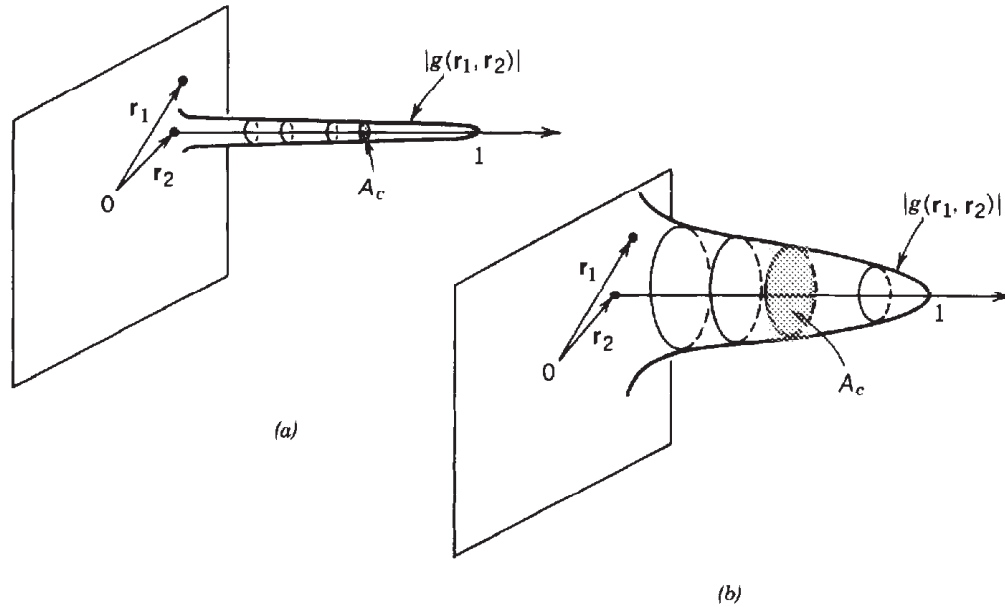

Figure 10.1-8 Two illustrative examples of the magnitude of the normalized mutual intensity as a function of \mathbf{r}_1 in the vicinity of a fixed point \mathbf{r}_2 . The coherence area in (a) is smaller than that in (b).

is the normalized mutual intensity. The magnitude $|g(\mathbf{r}_1, \mathbf{r}_2)|$ is bounded between zero and unity and is regarded as a measure of the degree of spatial coherence (when the time delay τ is zero). If the complex wavefunction $U(\mathbf{r}, t)$ is deterministic, $|g(\mathbf{r}_1, \mathbf{r}_2)| = 1$ for all \mathbf{r}_1 and \mathbf{r}_2 , so that the light is completely correlated everywhere.

Coherence Area

The spatial coherence of quasi-monochromatic light in a given plane in the vicinity of a given position \mathbf{r}_2 is described by $|g(\mathbf{r}_1, \mathbf{r}_2)|$ as a function of the distance $|\mathbf{r}_1 - \mathbf{r}_2|$. This function is unity when $\mathbf{r}_1 = \mathbf{r}_2$ and drops as $|\mathbf{r}_1 - \mathbf{r}_2|$ increases (but it need not be monotonic). The area scanned by the point \mathbf{r}_1 within which the function $|g(\mathbf{r}_1, \mathbf{r}_2)|$ is greater than some prescribed value ($\frac{1}{2}$ or $\frac{1}{e}$, for example) is called the **coherence area**. It represents the spatial extent of $|g(\mathbf{r}_1, \mathbf{r}_2)|$ as a function of \mathbf{r}_1 for fixed \mathbf{r}_2 , as illustrated in Fig. 10.1-8. In the ideal limit of coherent light the coherence area is infinite.

The coherence area is an important parameter that characterizes random light. This parameter must be considered in relation to other pertinent dimensions of the optical system. For example, if the area of coherence is greater than the size of the aperture through which light is transmitted, so that $|g(\mathbf{r}_1, \mathbf{r}_2)| \approx 1$ at all points of interest, the light may be regarded as coherent, as if the coherence area were infinite. Similarly, if the coherence area is smaller than the resolution of the optical system, it can be regarded as infinitesimal, i.e., $g(\mathbf{r}_1, \mathbf{r}_2) = 0$ for practically all $\mathbf{r}_1 \neq \mathbf{r}_2$. In this limit the light is said to be **incoherent**.

Light radiated from an extended radiating hot surface has an area of coherence on the order of λ^2 , where λ is the central wavelength, so that for most practical cases it may be regarded as incoherent. Thus complete coherence and incoherence are only idealizations representing the two limits of partial coherence.

Cross-Spectral Density

The mutual coherence function $G(\mathbf{r}_1, \mathbf{r}_2, \tau)$ describes the spatial correlation at each time delay τ . The time delay $\tau = 0$ is selected to define the mutual intensity $G(\mathbf{r}_1, \mathbf{r}_2)$

$= G(\mathbf{r}_1, \mathbf{r}_2, 0)$, which is suitable for describing the spatial coherence of quasi-monochromatic light. A useful alternative is to describe spatial coherence in the frequency domain by examining the spatial correlation at a fixed frequency. The **cross-spectral density** (or the cross-power spectrum) is defined as the Fourier transform of $G(\mathbf{r}_1, \mathbf{r}_2, \tau)$ with respect to τ :

$$S(\mathbf{r}_1, \mathbf{r}_2, \nu) = \int_{-\infty}^{\infty} G(\mathbf{r}_1, \mathbf{r}_2, \tau) \exp(-j2\pi\nu\tau) d\tau. \quad (10.1-23)$$

Cross-Spectral Density

When $\mathbf{r}_1 = \mathbf{r}_2 = \mathbf{r}$, the cross-spectral density becomes the power-spectral density $S(\nu)$ at position \mathbf{r} , as defined in (10.1-14).

The normalized cross-spectral density is defined by

$$s(\mathbf{r}_1, \mathbf{r}_2, \nu) = \frac{S(\mathbf{r}_1, \mathbf{r}_2, \nu)}{[S(\mathbf{r}_1, \mathbf{r}_1, \nu)S(\mathbf{r}_2, \mathbf{r}_2, \nu)]^{1/2}}, \quad (10.1-24)$$

and its magnitude can be shown to be bounded between zero and unity, so that it serves as a measure of the degree of spatial coherence at the frequency ν . It represents the correlatedness of the fluctuation components of frequency ν at positions \mathbf{r}_1 and \mathbf{r}_2 .

In certain cases, the cross-spectral density factors into a product of one function of position and another of frequency, $S(\mathbf{r}_1, \mathbf{r}_2, \nu) = G(\mathbf{r}_1, \mathbf{r}_2)s(\nu)$, so that the spatial and spectral properties are separable. The light is then said to be **cross-spectrally pure**. The mutual coherence function must then also factor into a product of a function of position and another of time, $G(\mathbf{r}_1, \mathbf{r}_2, \tau) = G(\mathbf{r}_1, \mathbf{r}_2)g(\tau)$, where $g(\tau)$ is the inverse Fourier transform of $s(\nu)$. If the factorization parts are selected such that $\int s(\nu) d\nu = 1$, then $G(\mathbf{r}_1, \mathbf{r}_2) = G(\mathbf{r}_1, \mathbf{r}_2, 0)$, so that $G(\mathbf{r}_1, \mathbf{r}_2)$ is nothing but the mutual intensity. Cross-spectrally pure light has two important properties:

- At a single position \mathbf{r} , $S(\mathbf{r}, \mathbf{r}, \nu) = G(\mathbf{r}, \mathbf{r})s(\nu) = I(\mathbf{r})s(\nu)$. The spectrum has the same profiles at all positions. If the light represents a visible image, it would appear to have the same color everywhere but with varying brightness.
- The normalized cross-spectral density

$$s(\mathbf{r}_1, \mathbf{r}_2, \nu) = G(\mathbf{r}_1, \mathbf{r}_2) / [G(\mathbf{r}_1, \mathbf{r}_1)G(\mathbf{r}_2, \mathbf{r}_2)]^{1/2} = g(\mathbf{r}_1, \mathbf{r}_2)$$

is independent of frequency. In this case the normalized mutual intensity $g(\mathbf{r}_1, \mathbf{r}_2)$ describes spatial coherence at all frequencies.

D. Longitudinal Coherence

In this section the concept of longitudinal coherence is introduced by taking examples of random waves with fixed wavefronts, such as planar and spherical waves.

Partially Coherent Plane Wave

Consider a plane wave

$$U(\mathbf{r}, t) = a \left(t - \frac{z}{c} \right) \exp \left[j2\pi\nu_0 \left(t - \frac{z}{c} \right) \right] \quad (10.1-25)$$

traveling in the z direction in a homogeneous medium with velocity c . As shown in Sec.

2.6A, $U(\mathbf{r}, t)$ satisfies the wave equation for an arbitrary function $a(t)$. If $a(t)$ is a random function, $U(\mathbf{r}, t)$ represents partially coherent light. The mutual coherence function defined in (10.1-17) is

$$G(\mathbf{r}_1, \mathbf{r}_2, \tau) = G_a\left(\tau - \frac{z_2 - z_1}{c}\right) \exp\left[j2\pi\nu_0\left(\tau - \frac{z_2 - z_1}{c}\right)\right], \quad (10.1-26)$$

where z_1 and z_2 are the z components of \mathbf{r}_1 and \mathbf{r}_2 and $G_a(\tau) = \langle a^*(t)a(t + \tau) \rangle$ is the autocorrelation function of $a(t)$, assumed to be independent of t .

The intensity $I(\mathbf{r}) = G(\mathbf{r}, \mathbf{r}, 0) = G_a(0)$ is constant everywhere in space. Temporal coherence is characterized by the time function $G(\mathbf{r}, \mathbf{r}, \tau) = G_a(\tau) \exp(j2\pi\nu_0\tau)$, which is independent of position. The complex degree of coherence is $g(\mathbf{r}, \mathbf{r}, \tau) = g_a(\tau) \exp(j2\pi\nu_0\tau)$, where $g_a(\tau) = G_a(\tau)/G_a(0)$. The width of $|g_a(\tau)| = |g(\mathbf{r}, \mathbf{r}, \tau)|$, defined by an expression similar to (10.1-9), is the coherence time τ_c . It is the same at all positions.

The power spectral density is the Fourier transform of $G(\mathbf{r}, \mathbf{r}, \tau)$ with respect to τ . From (10.1-26), $S(\nu)$ is seen to be equal to the Fourier transform of $G_a(\tau)$ shifted by a frequency ν_0 (in accordance with the frequency shift property of the Fourier transform defined in Appendix A, Sec. A.1). The wave therefore has the same power spectral density everywhere in space.

The spatial coherence properties are described by

$$G(\mathbf{r}_1, \mathbf{r}_2, 0) = G_a\left(\frac{z_1 - z_2}{c}\right) \exp\left[\frac{j2\pi\nu_0(z_1 - z_2)}{c}\right] \quad (10.1-27)$$

and its normalized version,

$$g(\mathbf{r}_1, \mathbf{r}_2, 0) = g_a\left(\frac{z_1 - z_2}{c}\right) \exp\left[\frac{j2\pi\nu_0(z_1 - z_2)}{c}\right]. \quad (10.1-28)$$

If the two points \mathbf{r}_1 and \mathbf{r}_2 lie in the same transverse plane, i.e., $z_1 = z_2$, then $|g(\mathbf{r}_1, \mathbf{r}_2, 0)| = |g_a(0)| = 1$. This means that fluctuations at points on a wavefront (a plane normal to the z axis) are completely correlated; the coherence area in any transverse plane is infinite (Fig. 10.1-9). On the other hand, fluctuations at two points separated by an axial distance $z_2 - z_1$ such that $|z_2 - z_1|/c > \tau_c$, or $|z_2 - z_1| > l_c$, where $l_c = c\tau_c$ is the coherence length, are approximately uncorrelated.

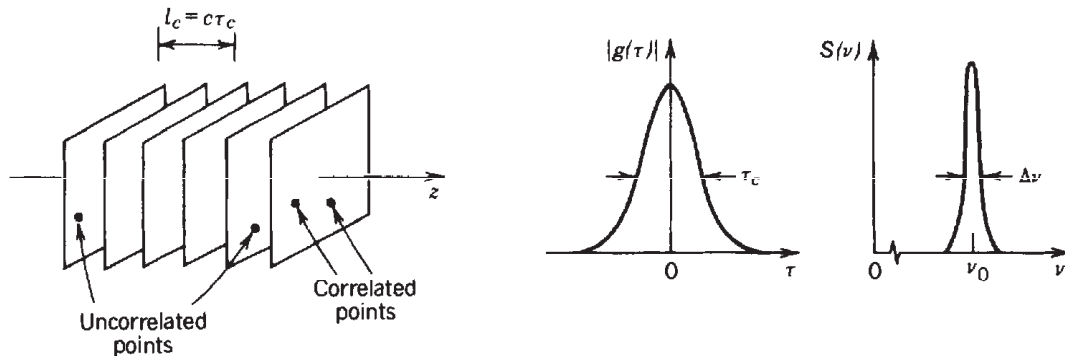

Figure 10.1-9 The fluctuations of a partially coherent plane wave at points on any wavefront (transverse plane) are completely correlated, whereas those at points on wavefronts separated by an axial distance greater than the coherence length $l_c = c\tau_c$ are approximately uncorrelated.

In summary: The partially coherent plane wave is spatially coherent within each transverse plane, but partially coherent in the axial direction. The axial (longitudinal) spatial coherence of the wave has a one-to-one correspondence with the temporal coherence. The ratio of the coherence length $l_c = c\tau_c$ to the maximum optical path difference l_{\max} in the system governs the role played by coherence. If $l_c \gg l_{\max}$, the wave is effectively completely coherent. The coherence lengths of a number of light sources are listed in Table 10.1-2.

Partially Coherent Spherical Wave

A partially coherent spherical wave is described by the complex wavefunction (see Secs. 2.2B and 2.6A)

$$U(\mathbf{r}, t) = \frac{1}{r} a\left(t - \frac{r}{c}\right) \exp\left[j2\pi\nu_0\left(t - \frac{r}{c}\right)\right], \quad (10.1-29)$$

where $a(t)$ is a random function. The corresponding mutual coherence function is

$$G(\mathbf{r}_1, \mathbf{r}_2, \tau) = \frac{1}{r_1 r_2} G_a\left(\tau - \frac{r_2 - r_1}{c}\right) \exp\left[j2\pi\nu_0\left(\tau - \frac{r_2 - r_1}{c}\right)\right], \quad (10.1-30)$$

with $G_a(\tau) = \langle a^*(t)a(t+\tau) \rangle$.

The intensity $I(\mathbf{r}) = G_a(0)/r^2$ varies in accordance with an inverse-square law. The coherence time τ_c is the width of the function $|g_a(\tau)| = |G_a(\tau)/G_a(0)|$. It is the same everywhere in space. So is the power spectral density. For $\tau = 0$, fluctuations at all points on a wavefront (a sphere) are completely correlated, whereas fluctuations at points on two wavefronts separated by the radial distance $|r_2 - r_1| \gg l_c = c\tau_c$ are uncorrelated (see Fig. 10.1-10).

An arbitrary partially coherent wave transmitted through a pinhole generates a partially coherent spherical wave. This process therefore imparts spatial coherence to the incoming wave (points on any sphere centered about the pinhole become completely correlated). However, the wave remains temporally partially coherent. Points at different distances from the pinhole are only partially correlated. *The pinhole imparts spatial coherence but not temporal coherence to the wave.*

Suppose now that an optical filter of very narrow spectral width is placed at the pinhole, so that the transmitted wave becomes approximately monochromatic. The wave will then have complete temporal, as well as spatial, coherence. Temporal coherence is introduced by the narrowband filter, whereas spatial coherence is imparted by the pinhole, which acts as a spatial filter. The price for obtaining this ideal wave is, of course, the loss of optical energy introduced by the temporal and spatial filtering processes.

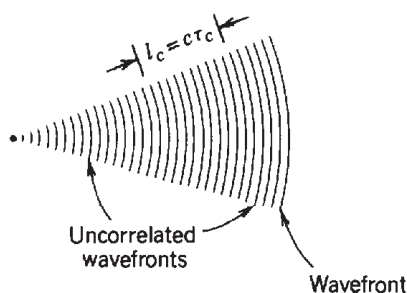

Figure 10.1-10 A partially coherent spherical wave has complete spatial coherence at all points on a wavefront, but not at points with different radial distances.

10.2 INTERFERENCE OF PARTIALLY COHERENT LIGHT

The interference of *coherent* light was discussed in Sec. 2.5. This section is devoted to the interference of *partially coherent* light.

A. Interference of Two Partially Coherent Waves

The statistical properties of two partially coherent waves U_1 and U_2 are described not only by their own mutual coherence functions but also by a measure of the degree to which their fluctuations are correlated. At a given position \mathbf{r} and time t , the intensities of the two waves are $I_1 = \langle |U_1|^2 \rangle$ and $I_2 = \langle |U_2|^2 \rangle$, whereas their cross-correlation is described by the statistical average $G_{12} = \langle U_1^* U_2 \rangle$, and its normalized version

$$g_{12} = \frac{\langle U_1^* U_2 \rangle}{(I_1 I_2)^{1/2}}. \quad (10.2-1)$$

When the two waves are superposed, the average intensity of their sum is

$$\begin{aligned} I &= \langle |U_1 + U_2|^2 \rangle = \langle |U_1|^2 \rangle + \langle |U_2|^2 \rangle + \langle U_1^* U_2 \rangle + \langle U_1 U_2^* \rangle \\ &= I_1 + I_2 + G_{12} + G_{12}^* = I_1 + I_2 + 2 \operatorname{Re}\{G_{12}\} \\ &= I_1 + I_2 + 2(I_1 I_2)^{1/2} \operatorname{Re}\{g_{12}\}, \end{aligned} \quad (10.2-2)$$

from which

$$I = I_1 + I_2 + 2(I_1 I_2)^{1/2} |g_{12}| \cos \varphi, \quad (10.2-3)$$

Interference Equation

where $\varphi = \arg\{g_{12}\}$ is the phase of g_{12} . The third term on the right-hand side of (10.2-3) represents optical interference.

There are two important limits:

- For two *completely correlated* waves with $g_{12} = \exp(j\varphi)$ and $|g_{12}| = 1$, we recover the interference formula (2.5-4) for two coherent waves of phase difference φ .
- For two *uncorrelated* waves with $g_{12} = 0$, $I = I_1 + I_2$, so that there is no interference.

In the general case, the normalized intensity I versus the phase φ assumes the form of a sinusoidal pattern, as shown in Fig. 10.2-1. The strength of the interference is measured by the visibility \mathcal{V} , also called the modulation depth or the contrast of the interference pattern

$$\mathcal{V} = \frac{I_{\max} - I_{\min}}{I_{\max} + I_{\min}},$$

where I_{\max} and I_{\min} are the maximum and minimum values that I takes as φ is varied. Since $\cos \varphi$ stretches between 1 and -1 , (10.2-3) yields

$$\mathcal{V} = \frac{2(I_1 I_2)^{1/2}}{(I_1 + I_2)} |g_{12}|. \quad (10.2-4)$$

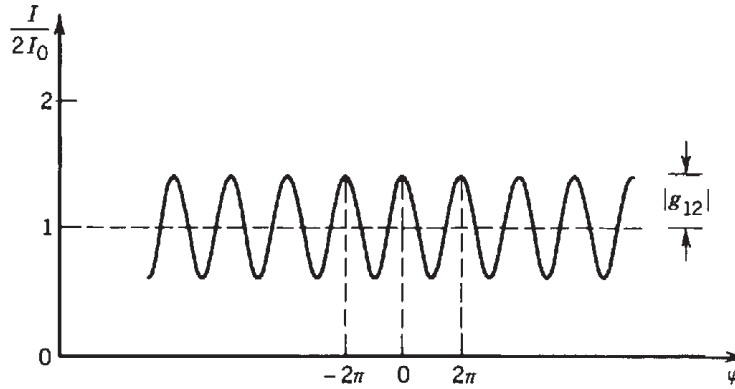

Figure 10.2-1 The normalized intensity $I/2I_0$ of the sum of two partially coherent waves of equal intensities $I_1 = I_2 = I_0$ as a function of the phase φ of their normalized cross-correlation g_{12} . This sinusoidal pattern has visibility $\mathcal{V} = |g_{12}|$.

The visibility is therefore proportional to the absolute value of the normalized cross-correlation $|g_{12}|$. If $I_1 = I_2$,

$$\boxed{\mathcal{V} = |g_{12}|} \tag{10.2-5}$$

Visibility

The interference equation (10.2-3) will now be applied to a number of special cases to illustrate the effects of temporal and spatial coherence on the interference of partially coherent light.

B. Interference and Temporal Coherence

Consider a partially coherent wave $U(t)$ with intensity I_0 and complex degree of temporal coherence $g(\tau) = \langle U^*(t)U(t + \tau) \rangle / I_0$. If $U(t)$ is added to a replica of itself delayed by the time τ , $U(t + \tau)$, what is the intensity I of the superposition?

Using the interference formula (10.2-3) with $U_1 = U(t)$, $U_2 = U(t + \tau)$, $I_1 = I_2 = I_0$, and $g_{12} = \langle U_1^*U_2 \rangle / I_0 = \langle U^*(t)U(t + \tau) \rangle / I_0 = g(\tau)$, we obtain

$$I = 2I_0[1 + \text{Re}\{g(\tau)\}] = 2I_0[1 + |g(\tau)|\cos \varphi(\tau)], \tag{10.2-6}$$

where $\varphi(\tau) = \arg\{g(\tau)\}$. *The ability of a wave to interfere with a time delayed replica of itself is governed by its complex degree of temporal coherence at that time delay.*

A wave may be added to a time-delayed replica of itself by using a beamsplitter to generate two identical waves, one of which is made to travel a longer optical path before the two waves are recombined using another (or the same) beamsplitter. This may be achieved by using a Mach-Zehnder or a Michelson interferometer, for example (see Fig. 2.5-3).

Consider, as an example, the partially coherent plane wave introduced in Sec. 10.1D [equation (10.1-25)] whose complex degree of temporal coherence is $g(\tau) = g_a(\tau) \exp(j2\pi\nu_0\tau)$. The spectral width of the wave is $\Delta\nu_c = 1/\tau_c$, where τ_c , the width of $|g_a(\tau)|$, is the coherence time. Substituting into (10.2-6), we obtain

$$I = 2I_0\{1 + |g_a(\tau)|\cos[2\pi\nu_0\tau + \varphi_a(\tau)]\}, \tag{10.2-7}$$

where $\varphi_a(\tau) = \arg\{g_a(\tau)\}$.

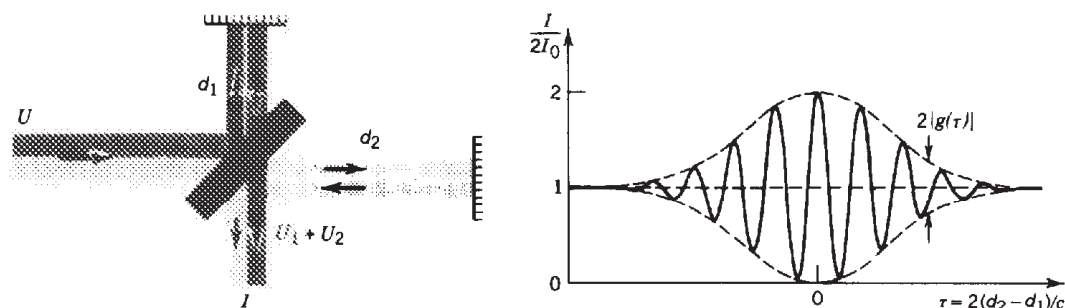

Figure 10.2-2 The normalized intensity $I/2I_0$ as a function of time delay τ when a partially coherent plane wave is introduced into a Michelson interferometer. The visibility equals the magnitude of the complex degree of temporal coherence.

The relation between I and τ is known as an **interferogram** (Fig. 10.2-2). Assuming that $\Delta\nu_c \ll \nu_0$, the functions $|g_a(\tau)|$ and $\varphi_a(\tau)$ vary slowly in comparison to the period $1/\nu_0$ since $\Delta\nu_c = 1/\tau_c \ll \nu_0$. The visibility of this interferogram in the vicinity of a particular time delay τ is $\mathcal{V} = |g(\tau)| = |g_a(\tau)|$. It has a peak value of unity near $\tau = 0$ and vanishes for $\tau \gg \tau_c$, i.e., when the optical path difference is much greater than the coherence length $l_c = c\tau_c$. For the Michelson interferometer shown in Fig. 10.2-2, $\tau = 2(d_2 - d_1)/c$. Interference occurs only when the optical path difference is smaller than the coherence length.

The magnitude of the complex degree of temporal coherence of a wave $|g(\tau)|$ may therefore be measured by monitoring the visibility of the interference pattern as a function of time delay. The phase of $g(\tau)$ may be measured by observing the locations of the peaks of the pattern.

It is revealing to write (10.2-6) in terms of the power spectral density. Using the Fourier transform relation between $G(\tau)$ and $S(\nu)$,

$$G(\tau) = I_0 g(\tau) = \int_0^\infty S(\nu) \exp(j2\pi\nu\tau) d\nu,$$

substituting into (10.2-6), and noting that $S(\nu)$ is real and $\int_0^\infty S(\nu) d\nu = I_0$, we obtain

$$I = 2 \int_0^\infty S(\nu) [1 + \cos(2\pi\nu\tau)] d\nu. \quad (10.2-8)$$

This equation can be interpreted as a weighted superposition of interferograms produced by each of the monochromatic components of the wave. Each component ν produces an interferogram with period $1/\nu$ and unity visibility, but the composite interferogram has reduced visibility as a result of the different periods.

Equation (10.2-8) suggests a technique for determining the spectral density $S(\nu)$ of a light source by measuring the interferogram I versus τ and then inverting it by means of Fourier-transform methods. This technique is known as **Fourier-transform spectroscopy**.

C. Interference and Spatial Coherence

The effect of spatial coherence on interference is demonstrated by considering the Young's double-pinhole interference experiment, discussed in Exercise 2.5-2 for coherent light. A partially coherent optical wave $U(\mathbf{r}, t)$ illuminates an opaque screen with two pinholes located at positions \mathbf{r}_1 and \mathbf{r}_2 . The wave has mutual coherence function

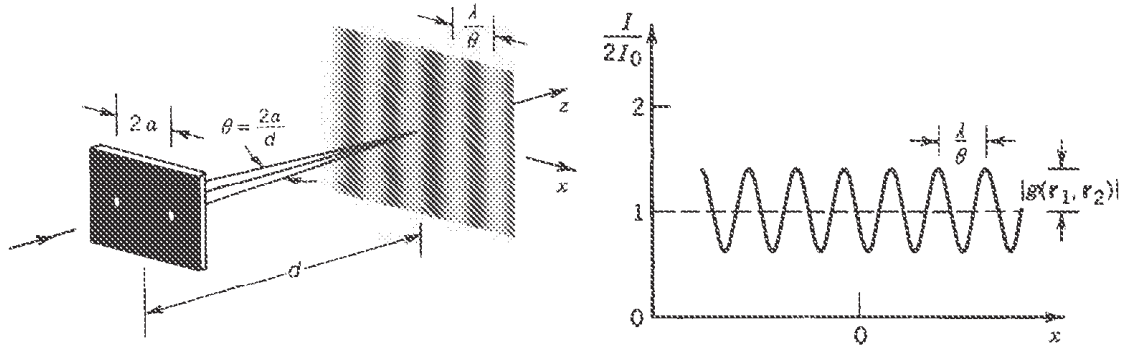

Figure 10.2-3 Young's double-pinhole interferometer. The incident wave is quasi-monochromatic and the normalized mutual intensity at the pinholes is $g(\mathbf{r}_1, \mathbf{r}_2)$. The normalized intensity $I/2I_0$ in the observation plane at a large distance is a sinusoidal function of x with period λ/θ and visibility $\mathcal{V} = |g(\mathbf{r}_1, \mathbf{r}_2)|$.

$G(\mathbf{r}_1, \mathbf{r}_2, \tau) = \langle U^*(\mathbf{r}_1, t)U(\mathbf{r}_2, t + \tau) \rangle$ and complex degree of coherence $g(\mathbf{r}_1, \mathbf{r}_2, \tau)$. The intensities at the pinholes are assumed to be equal.

Light is diffracted in the form of two spherical waves centered at the pinholes. The two waves interfere, and the intensity I of their sum is observed at a point \mathbf{r} in the observation plane a distance d from the screen sufficiently large so that the paraboloidal approximation is applicable. In Cartesian coordinates (Fig. 10.2-3) $\mathbf{r}_1 = (-a, 0, 0)$, $\mathbf{r}_2 = (a, 0, 0)$, and $\mathbf{r} = (x, 0, d)$. The intensity is observed as a function of x . An important geometrical parameter is the angle $\theta \approx 2a/d$ subtended by the two pinholes.

In the paraboloidal (Fresnel) approximation [see (2.2-16)], the two diffracted spherical waves are approximately related to $U(\mathbf{r}, t)$ by

$$U_1(\mathbf{r}, t) \propto U\left(\mathbf{r}_1, t - \frac{|\mathbf{r} - \mathbf{r}_1|}{c}\right) \approx U\left(\mathbf{r}_1, t - \frac{d + (x + a)^2/2d}{c}\right) \quad (10.2-9a)$$

$$U_2(\mathbf{r}, t) \propto U\left(\mathbf{r}_2, t - \frac{|\mathbf{r} - \mathbf{r}_2|}{c}\right) \approx U\left(\mathbf{r}_2, t - \frac{d + (x - a)^2/2d}{c}\right), \quad (10.2-9b)$$

and have approximately equal intensities, $I_1 = I_2 = I_0$. The normalized cross-correlation between the two waves at \mathbf{r} is

$$g_{12} = \frac{\langle U_1^*(\mathbf{r}, t)U_2(\mathbf{r}, t) \rangle}{I_0} = g(\mathbf{r}_1, \mathbf{r}_2, \tau_x), \quad (10.2-10)$$

where

$$\tau_x = \frac{|\mathbf{r} - \mathbf{r}_1| - |\mathbf{r} - \mathbf{r}_2|}{c} = \frac{(x + a)^2 - (x - a)^2}{2dc} = \frac{2ax}{dc} = \frac{\theta}{c}x \quad (10.2-11)$$

is the difference in the time delays encountered by the two waves.

Substituting (10.2-10) into the interference formula (10.2-3) gives rise to an observed intensity $I \equiv I(x)$:

$$I(x) = 2I_0[1 + |g(\mathbf{r}_1, \mathbf{r}_2, \tau_x)| \cos \varphi_x], \quad (10.2-12)$$

where $\varphi_x = \arg\{g(\mathbf{r}_1, \mathbf{r}_2, \tau_x)\}$. This equation describes the pattern of observed intensity as a function of position x in the observation plane, in terms of the magnitude and phase of the complex degree of coherence at the pinholes at time delay $\tau_x = \theta x/c$.

Quasi-Monochromatic Light

If the light is quasi-monochromatic with central frequency ν_0 , i.e., if $g(\mathbf{r}_1, \mathbf{r}_2, \tau) \approx g(\mathbf{r}_1, \mathbf{r}_2) \exp(j2\pi\nu_0\tau)$, then (10.2-12) gives

$$I(x) = 2I_0 \left[1 + \mathcal{V} \cos \left(\frac{2\pi\theta}{\lambda} x + \varphi \right) \right], \quad (10.2-13)$$

where $\lambda = c/\nu_0$, $\mathcal{V} = |g(\mathbf{r}_1, \mathbf{r}_2)|$, $\tau_x = \theta x/c$, and $\varphi = \arg\{g(\mathbf{r}_1, \mathbf{r}_2)\}$. The interference fringe pattern is therefore sinusoidal with spatial period λ/θ and visibility \mathcal{V} . In analogy with the temporal case, *the visibility of the interference pattern equals the magnitude of the complex degree of spatial coherence at the two pinholes* (Fig. 10.2-3). The locations of the peaks depend on the phase φ .

Interference with Light from an Extended Source

If the incident wave in Young's interferometer is a coherent plane wave traveling in the z direction, $U(\mathbf{r}, t) = \exp(-jkz) \exp(j2\pi\nu_0 t)$, then $g(\mathbf{r}_1, \mathbf{r}_2) = 1$, so that $|g(\mathbf{r}_1, \mathbf{r}_2)| = 1$, and $\arg\{g(\mathbf{r}_1, \mathbf{r}_2)\} = 0$. The interference pattern therefore has unity visibility and a peak at $x = 0$. But if the illumination is, instead, a tilted plane wave arriving from a direction in the x - z plane making a small angle θ_x with respect to the z axis, i.e., $U(\mathbf{r}, t) \approx \exp[-j(kz + k\theta_x x)] \exp(j2\pi\nu_0 t)$, then $g(\mathbf{r}_1, \mathbf{r}_2) = \exp(-jk\theta_x 2a)$. The visibility remains $\mathcal{V} = 1$, but the tilt results in a phase shift $\varphi = -k\theta_x 2a = -2\pi\theta_x 2a/\lambda$, so that the interference pattern is shifted laterally by a fraction $(2a\theta_x/\lambda)$ of a period. When $\varphi = 2\pi$, the pattern is shifted one period.

Suppose now that the incident light is a collection of independent plane waves arriving from a source that subtends an angle θ_s at the pinhole plane (Fig. 10.2-4). The phase shift φ then takes values in the range $\pm 2\pi(\theta_s/2)2a/\lambda = \pm 2\pi\theta_s a/\lambda$ and the fringe pattern is a superposition of displaced sinusoids. If $\theta_s = \lambda/2a$ then φ takes on values in the range $\pm\pi$, which is sufficient to wash out the interference pattern and reduce its visibility to zero.

We conclude that the degree of spatial coherence at the two pinholes is very small when the angle subtended by the source is $\theta_s = \lambda/2a$ (or greater). Consequently, the distance

$$\rho_c \approx \frac{\lambda}{\theta_s}$$

$$(10.2-14)$$

Coherence Distance

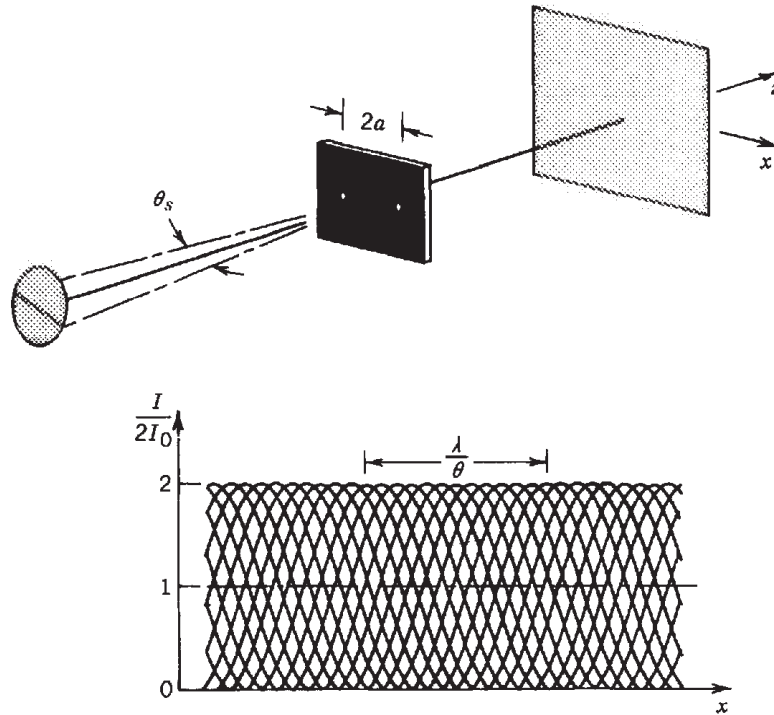

Figure 10.2-4 Young's interference fringes are washed out if the illumination emanates from a source of angular diameter $\theta_s > \lambda/2a$. If the distance $2a$ is smaller than λ/θ_s , the fringes become visible.

is a measure of the coherence distance in the plane of the screen and

$$A_c \approx \left(\frac{\lambda}{\theta_s} \right)^2 \quad (10.2-15)$$

is a measure of the coherence area of light emitted from a source subtending an angle θ_s . The angle subtended by the sun, for example, is 0.5° , so that the coherence distance for filtered sunlight of wavelength λ is $\rho_c \approx \lambda/\theta_s \approx 115\lambda$. At $\lambda = 0.5 \mu\text{m}$, $\rho_c \approx 57.5 \mu\text{m}$.

A more rigorous analysis (see Sec. 10.3C) shows that the transverse coherence distance ρ_c for a circular incoherent light source of uniform intensity is

$$\rho_c = 1.22 \frac{\lambda}{\theta_s}. \quad (10.2-16)$$

Effect of Spectral Width on Interference

Finally, we examine the effect of the spectral width on interference in the Young's double-pinhole interferometer. The power spectral density of the incident wave is assumed to be a narrow function of width $\Delta\nu_c$ centered about ν_0 , and $\Delta\nu_c \ll \nu_0$. The complex degree of coherence then has the form

$$g(\mathbf{r}_1, \mathbf{r}_2, \tau) = g_a(\mathbf{r}_1, \mathbf{r}_2, \tau) \exp(j2\pi\nu_0\tau), \quad (10.2-17)$$

where $g_a(\mathbf{r}_1, \mathbf{r}_2, \tau)$ is a slowly varying function of τ (in comparison with the period

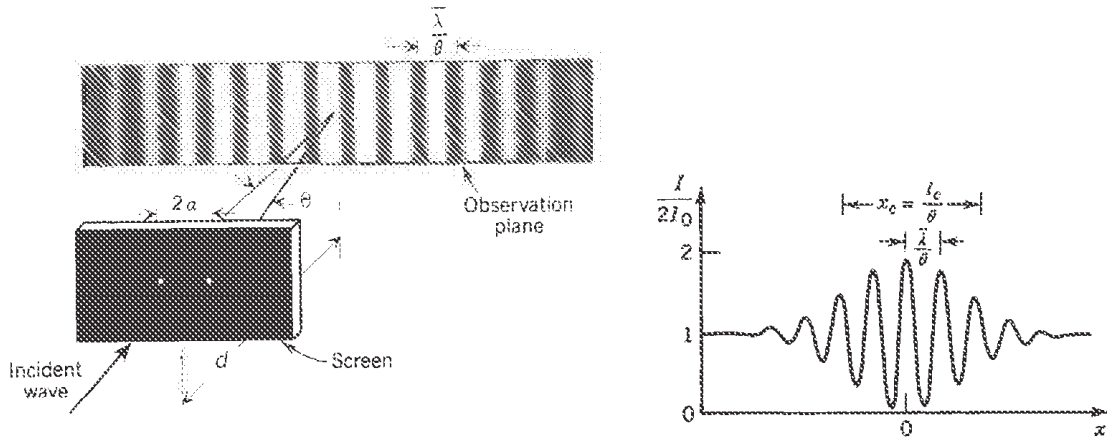

Figure 10.2-5 The visibility of Young's interference fringes at position x is the magnitude of the complex degree of coherence at the pinholes at a time delay $\tau_x = \theta x/c$. For spatially coherent light the number of observable fringes is the ratio of the coherence length to the central wavelength, or the ratio of the central frequency to the spectral linewidth.

$1/\nu_0$). Substituting (10.2-17) into (10.2-12), we obtain

$$I(x) = 2I_0 \left[1 + \mathcal{V}_x \cos \left(\frac{2\pi\theta}{\lambda} x + \varphi_x \right) \right], \quad (10.2-18)$$

where $\mathcal{V}_x = |g_a(\mathbf{r}_1, \mathbf{r}_2, \tau_x)|$, $\varphi_x = \arg\{g_a(\mathbf{r}_1, \mathbf{r}_2, \tau_x)\}$, $\tau_x = \theta x/c$, and $\bar{\lambda} = c/\nu_0$.

Thus the interference pattern is sinusoidal with period $\bar{\lambda}/\theta$ but with a varying visibility \mathcal{V}_x and varying phase φ_x equal to the magnitude and phase of the complex degree of coherence at the two pinholes, respectively, evaluated at the time delay $\tau_x = \theta x/c$. If $|g_a(\mathbf{r}_1, \mathbf{r}_2, \tau)| = 1$ at $\tau = 0$, decreases with increasing τ , and vanishes for $\tau \gg \tau_c$, the visibility $\mathcal{V}_x = 1$ at $x = 0$, decreases with increasing x , and vanishes for $x \gg x_c = c\tau_c/\theta$. The interference pattern is then visible over a distance

$$x_c = \frac{l_c}{\theta}, \quad (10.2-19)$$

where $l_c = c\tau_c$ is the coherence length and θ is the angle subtended by the two pinholes (Fig. 10.2-5).

The number of observable fringes is thus $x_c/(\bar{\lambda}/\theta) = l_c/\bar{\lambda} = c\tau_c/\bar{\lambda} = \nu_0/\Delta\nu_c$. It equals the ratio $l_c/\bar{\lambda}$ of the coherence length to the central wavelength, or the ratio $\nu_0/\Delta\nu_c$ of the central frequency to the linewidth. Clearly, if $|g(\mathbf{r}_1, \mathbf{r}_2, 0)| < 1$, i.e., if the source is not spatially coherent, the visibility will be further reduced and even fewer fringes will be observable.

*10.3 TRANSMISSION OF PARTIALLY COHERENT LIGHT THROUGH OPTICAL SYSTEMS

The transmission of coherent light through thin optical components, through apertures, and through free space was discussed in Chaps. 2 and 4. In this section we pursue the same goal for quasi-monochromatic partially coherent light. We assume that the spectral width is sufficiently small so that the coherence length $l_c = c\tau_c = c/\Delta\nu_c$ is

much greater than the differences of optical path lengths in the system. The mutual coherence function may then be approximated by $G(\mathbf{r}_1, \mathbf{r}_2, \tau) \approx G(\mathbf{r}_1, \mathbf{r}_2) \exp(j2\pi\nu_0\tau)$, where $G(\mathbf{r}_1, \mathbf{r}_2)$ is the mutual intensity and ν_0 is the central frequency.

It is noted at the outset that the transmission laws that apply to the deterministic function $U(\mathbf{r})$, which represents coherent light, apply also to the random function $U(\mathbf{r})$, which represents partially coherent light. However, for partially coherent light our interest is in the laws that govern statistical averages: the intensity $I(\mathbf{r})$ and the mutual intensity $G(\mathbf{r}_1, \mathbf{r}_2)$.

A. Propagation of Partially Coherent Light

Transmission Through Thin Optical Components

When a partially coherent wave is transmitted through a thin optical component characterized by an amplitude transmittance $\iota(x, y)$ the incident and transmitted waves are related by $U_2(\mathbf{r}) = \iota(\mathbf{r})U_1(\mathbf{r})$, where $\mathbf{r} = (x, y)$ is the position in the plane of the component (see Fig. 10.3-1). Using the definition of the mutual intensity, $G(\mathbf{r}_1, \mathbf{r}_2) = \langle U^*(\mathbf{r}_1)U(\mathbf{r}_2) \rangle$, we obtain

$$G_2(\mathbf{r}_1, \mathbf{r}_2) = \iota^*(\mathbf{r}_1)\iota(\mathbf{r}_2)G_1(\mathbf{r}_1, \mathbf{r}_2), \quad (10.3-1)$$

where $G_1(\mathbf{r}_1, \mathbf{r}_2)$ and $G_2(\mathbf{r}_1, \mathbf{r}_2)$ are the mutual intensities of the incident and transmitted light, respectively.

Since the intensity at position \mathbf{r} equals the mutual intensity at $\mathbf{r}_1 = \mathbf{r}_2 = \mathbf{r}$,

$$I_2(\mathbf{r}) = |\iota(\mathbf{r})|^2 I_1(\mathbf{r}). \quad (10.3-2)$$

The normalized mutual intensities defined by (10.1-22) therefore satisfy

$$|g_2(\mathbf{r}_1, \mathbf{r}_2)| = |g_1(\mathbf{r}_1, \mathbf{r}_2)|. \quad (10.3-3)$$

Although transmission through a thin optical component may change the intensity of partially coherent light, it does not alter the magnitude of its degree of spatial coherence. Naturally, if the complex amplitude transmittance of the component itself were random, the coherence of the transmitted light would be altered.

Transmission Through an Arbitrary Optical System

We next consider an arbitrary optical system—one that includes propagation in free space or transmission through thick optical components. It was shown in Chap. 4 that the complex amplitude $U_2(\mathbf{r})$ at a point $\mathbf{r} = (x, y)$ in the output plane of such a system is generally a weighted superposition integral comprising contributions from the complex amplitudes $U_1(\mathbf{r}')$ at points $\mathbf{r}' = (x', y')$ in the input plane (see Fig. 10.3-2),

$$U_2(\mathbf{r}) = \int h(\mathbf{r}; \mathbf{r}')U_1(\mathbf{r}') d\mathbf{r}', \quad (10.3-4)$$

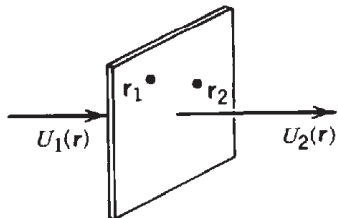

Figure 10.3-1 The absolute value of the degree of spatial coherence is not altered by transmission through a thin optical component.

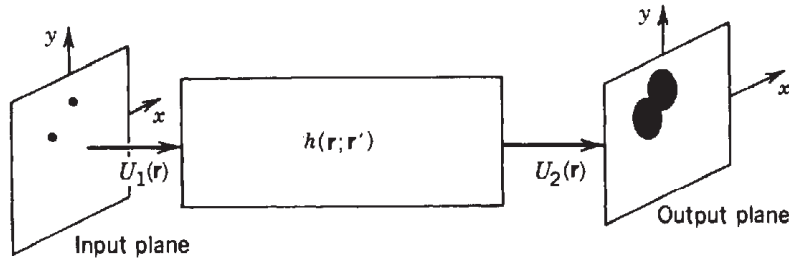

Figure 10.3-2 An optical system is characterized by its impulse-response function $h(\mathbf{r}; \mathbf{r}')$.

where $h(\mathbf{r}; \mathbf{r}')$ is the impulse-response function of the system. The integral in (10.3-4) is a double integral with respect to $\mathbf{r}' = (x', y')$ extending over the entire input plane.

To translate this relation between the random functions $U_2(\mathbf{r})$ and $U_1(\mathbf{r})$ into a relation between their mutual intensities, we substitute (10.3-4) into the definition $G_2(\mathbf{r}_1, \mathbf{r}_2) = \langle U_2^*(\mathbf{r}_1)U_2(\mathbf{r}_2) \rangle$ and use the definition $G_1(\mathbf{r}_1, \mathbf{r}_2) = \langle U_1^*(\mathbf{r}_1)U_1(\mathbf{r}_2) \rangle$ to obtain

$$G_2(\mathbf{r}_1, \mathbf{r}_2) = \iint h^*(\mathbf{r}_1; \mathbf{r}'_1)h(\mathbf{r}_2; \mathbf{r}'_2)G_1(\mathbf{r}'_1, \mathbf{r}'_2) d\mathbf{r}'_1 d\mathbf{r}'_2. \quad (10.3-5)$$

Image
Mutual Intensity

If the mutual intensity $G_1(\mathbf{r}_1, \mathbf{r}_2)$ of the input light and the impulse-response function $h(\mathbf{r}; \mathbf{r}')$ of the system are known, the mutual intensity of the output light $G_2(\mathbf{r}_1, \mathbf{r}_2)$ can be determined by carrying out the integrals in (10.3-5).

The intensity of the output light is obtained by using the definition $I_2(\mathbf{r}) = G_2(\mathbf{r}, \mathbf{r})$, which reduces (10.3-5) to

$$I_2(\mathbf{r}) = \iint h^*(\mathbf{r}; \mathbf{r}'_1)h(\mathbf{r}; \mathbf{r}'_2)G_1(\mathbf{r}'_1, \mathbf{r}'_2) d\mathbf{r}'_1 d\mathbf{r}'_2. \quad (10.3-6)$$

Image Intensity

To determine the intensity of the output light, we must know the mutual intensity of the input light. *Knowledge of the input intensity $I_1(\mathbf{r})$ by itself is generally not sufficient to determine the output intensity $I_2(\mathbf{r})$.*

B. Image Formation with Incoherent Light

We now consider the special case when the input light is incoherent. The mutual intensity $G_1(\mathbf{r}_1, \mathbf{r}_2)$ vanishes when \mathbf{r}_2 is only slightly separated from \mathbf{r}_1 so that the coherence distance is much smaller than other pertinent dimensions in the system (for example, the resolution distance of an imaging system). The mutual intensity may then be written in the form $G_1(\mathbf{r}_1, \mathbf{r}_2) = [I_1(\mathbf{r}_1)I_1(\mathbf{r}_2)]^{1/2}g(\mathbf{r}_1 - \mathbf{r}_2)$, where $g(\mathbf{r}_1 - \mathbf{r}_2)$ is a very narrow function. When $G_1(\mathbf{r}_1, \mathbf{r}_2)$ appears under the integral in (10.3-5) or (10.3-6) it is convenient to replace $g(\mathbf{r}_1 - \mathbf{r}_2)$ with a delta function, $g(\mathbf{r}_1 - \mathbf{r}_2) = \sigma\delta(\mathbf{r}_1 - \mathbf{r}_2)$, where $\sigma = \int g(\mathbf{r}) d\mathbf{r}$ is the area under $g(\mathbf{r})$, so that

$$G_1(\mathbf{r}_1, \mathbf{r}_2) \approx \sigma [I_1(\mathbf{r}_1)I_1(\mathbf{r}_2)]^{1/2}\delta(\mathbf{r}_1 - \mathbf{r}_2). \quad (10.3-7)$$

Since the mutual intensity must remain finite and $\delta(0) \rightarrow \infty$, this equation is clearly not generally accurate. It is valid only for the purpose of evaluating integrals such as in (10.3-6). Substituting (10.3-7) into (10.3-6), the delta function reduces the double integral into a single integral and we obtain

$$I_2(\mathbf{r}) = \int I_1(\mathbf{r}') h_i(\mathbf{r}; \mathbf{r}') d\mathbf{r}', \tag{10.3-8}$$

Imaging Equation
(Incoherent Illumination)

where

$$h_i(\mathbf{r}; \mathbf{r}') = \sigma |h(\mathbf{r}; \mathbf{r}')|^2. \tag{10.3-9}$$

Impulse-Response Function
(Incoherent Illumination)

Under these conditions, the relation between the intensities at the input and output planes describes a linear system of impulse-response function $h_i(\mathbf{r}; \mathbf{r}')$, also called the **point-spread function**. When the input light is completely incoherent, therefore, the intensity of the light at each point \mathbf{r} in the output plane is a weighted superposition of contributions from intensities at many points \mathbf{r}' of the input plane; interference does not occur and the intensities simply add (Fig. 10.3-3). This is to be contrasted with the completely coherent system, for which the complex amplitudes rather than intensities are related by a superposition integral, as in (10.3-4).

In certain optical systems the impulse-response function $h(\mathbf{r}; \mathbf{r}')$ is a function of $\mathbf{r} - \mathbf{r}'$, say $h(\mathbf{r} - \mathbf{r}')$. The system is then said to be **shift invariant** or **isoplanatic** (see Appendix B). In this case $h_i(\mathbf{r}; \mathbf{r}') = h_i(\mathbf{r} - \mathbf{r}')$. The integrals in (10.3-4) and (10.3-8) are then two-dimensional convolutions and the systems can be described by transfer functions $\mathcal{H}(\nu_x, \nu_y)$ and $\mathcal{H}_i(\nu_x, \nu_y)$, which are the Fourier transforms of $h(\mathbf{r}) = h(x, y)$ and $h_i(\mathbf{r}) = h_i(x, y)$, respectively.

As an example, we apply the relations above to an imaging system. It was shown in Sec. 4.4C that with coherent illumination, the impulse-response function of the

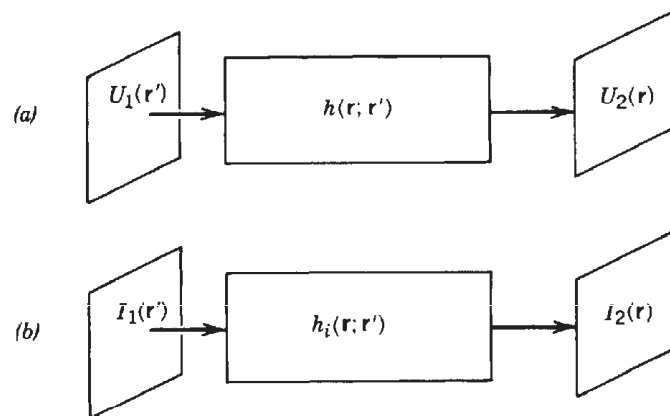

Figure 10.3-3 (a) The complex *amplitudes* of light at the input and output planes of an optical system illuminated by *coherent* light are related by a linear system with impulse-response function $h(\mathbf{r}; \mathbf{r}')$. (b) The *intensities* of light at the input and output planes of an optical system illuminated by *incoherent* light are related by a linear system with impulse-response function $h_i(\mathbf{r}; \mathbf{r}') = \sigma |h(\mathbf{r}; \mathbf{r}')|^2$.

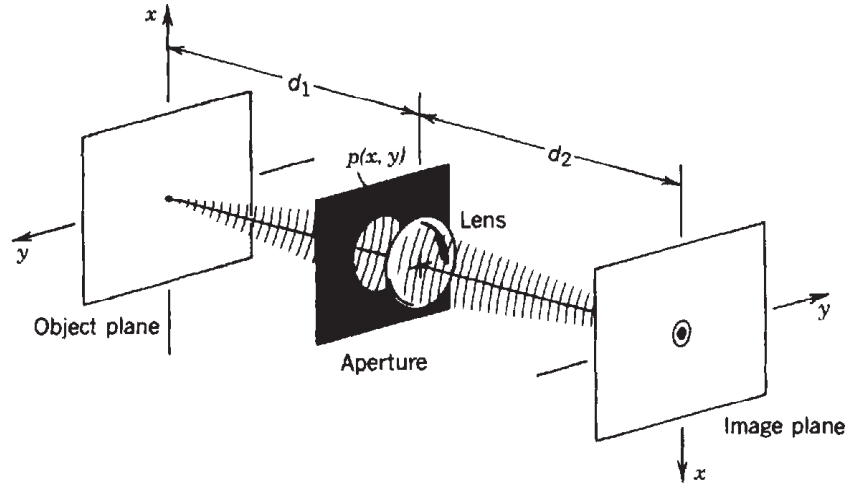

Figure 10.3-4 A single-lens imaging system.

single-lens focused imaging system illustrated in Fig. 10.3-4 in the Fresnel approximation is

$$h(\mathbf{r}) \propto P\left(\frac{x}{\lambda d_2}, \frac{y}{\lambda d_2}\right), \quad (10.3-10)$$

where $P(\nu_x, \nu_y)$ is the Fourier transform of the pupil function $p(x, y)$ and d_2 is the distance from the lens to the image plane. The pupil function is unity within the aperture and zero elsewhere.

When the illumination is quasi-monochromatic and spatially incoherent, the intensities of light at the object and image plane are linearly related by a system with impulse-response function

$$h_i(\mathbf{r}) = \sigma |h(\mathbf{r})|^2 \propto \left| P\left(\frac{x}{\lambda d_2}, \frac{y}{\lambda d_2}\right) \right|^2, \quad (10.3-11)$$

where λ is the wavelength corresponding to the central frequency ν_0 .

EXAMPLE 10.3-1. Imaging System with a Circular Aperture. If the aperture is a circle of radius a , the pupil function $p(x, y) = 1$ for x, y inside the circle, and 0 elsewhere. Its Fourier transform is

$$P(\nu_x, \nu_y) = \frac{a J_1(2\pi \nu_\rho a)}{\nu_\rho}, \quad \nu_\rho = (\nu_x^2 + \nu_y^2)^{1/2},$$

where $J_1(\cdot)$ is the Bessel function (see Appendix A, Sec. A.3). The impulse-response function of the coherent system is obtained by substituting into (10.3-10),

$$h(x, y) \propto \left[\frac{J_1(2\pi \nu_s \rho)}{\pi \nu_s \rho} \right], \quad \rho = (x^2 + y^2)^{1/2}, \quad (10.3-12)$$

where

$$\nu_s = \frac{\theta}{2\lambda}, \quad \theta = \frac{2a}{d_2}. \quad (10.3-13)$$

For incoherent illumination, the impulse-response function is therefore

$$h_i(x, y) \propto \left[\frac{J_1(2\pi\nu_s\rho)}{\pi\nu_s\rho} \right]^2. \quad (10.3-14)$$

The response functions $h(x, y)$ and $h_i(x, y)$ are illustrated in Fig. 10.3-5. Both functions reach their first zero when $2\pi\nu_s\rho = 3.832$, or $\rho = \rho_s \approx 3.832/2\pi\nu_s = 3.832\lambda/\pi\theta$, from which

$$\rho_s \approx 1.22 \frac{\lambda}{\theta}. \quad (10.3-15)$$

Two-Point Resolution

Thus the image of a point (impulse) in the input plane is a patch of intensity $h_i(x, y)$ and radius ρ_s . When the input distribution is composed of two points (impulses) separated by a distance ρ_s , the image of one point vanishes at the center of the image of the other point. The distance ρ_s is therefore a measure of the resolution of the imaging system.

The transfer functions of linear systems (see Appendix B) with the impulse-response functions $h(x, y)$ and $h_i(x, y)$ are the Fourier transforms (see Appendix A),

$$\mathcal{H}(\nu_x, \nu_y) = \begin{cases} 1, & \nu_\rho < \nu_s \\ 0, & \text{otherwise,} \end{cases} \quad (10.3-16)$$

and

$$\mathcal{H}_i(\nu_x, \nu_y) = \begin{cases} \frac{2}{\pi} \left\{ \cos^{-1} \frac{\nu_\rho}{2\nu_s} - \frac{\nu_\rho}{2\nu_s} \left[1 - \left(\frac{\nu_\rho}{2\nu_s} \right)^2 \right]^{1/2} \right\}, & \nu_\rho < 2\nu_s \\ 0, & \text{otherwise,} \end{cases} \quad (10.3-17)$$

where $\nu_\rho = (\nu_x^2 + \nu_y^2)^{1/2}$. Both functions have been normalized such that their values at $\nu_\rho = 0$ are 1. These functions are illustrated in Fig. 10.3-5. For coherent illumination, the transfer function is flat and has a cutoff frequency $\nu_s = \theta/2\lambda$ lines/mm. For incoherent illumination, the transfer function drops approximately linearly with the spatial frequency and has a cutoff frequency $2\nu_s = \theta/\lambda$ lines/mm.

If the object is placed at infinity, i.e., $d_1 = \infty$, then $d_2 = f$, the focal length of the lens. The angle $\theta = 2a/f$ is then the inverse of the lens F -number, $F_\# = f/2a$. The cutoff frequencies ν_s and $2\nu_s$ are related to the lens F -number by

$$\text{Cutoff frequency (lines/mm)} = \begin{cases} \frac{1}{2\lambda F_\#} & \text{(coherent illumination)} \\ \frac{1}{\lambda F_\#} & \text{(incoherent illumination).} \end{cases} \quad (10.3-18)$$

One should not draw the false conclusion that incoherent illumination is superior to coherent illumination since it has twice the spatial bandwidth. The transfer functions of the two systems should not be compared directly since one describes imaging of the complex amplitude, whereas the other describes imaging of the intensity.

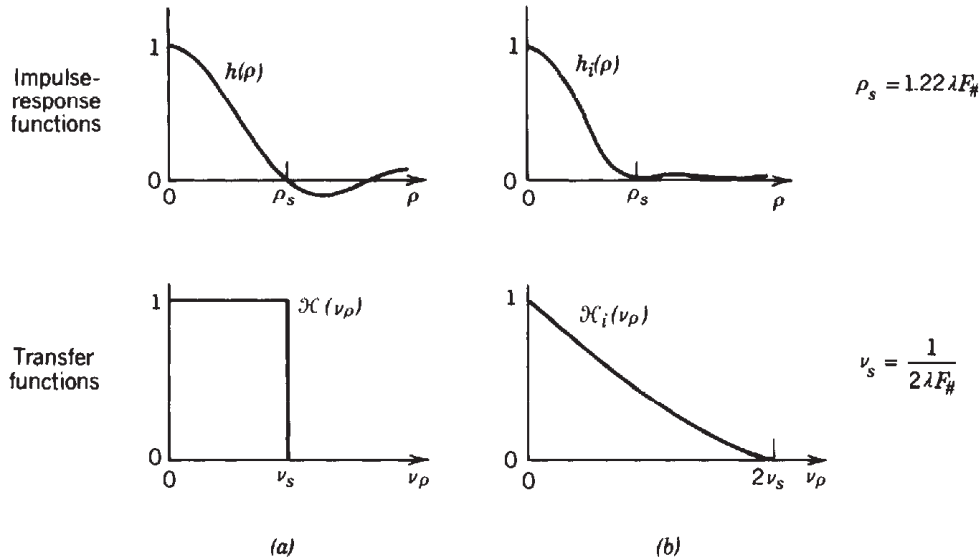

Figure 10.3-5 Impulse-response functions and transfer functions of a single-lens focused diffraction-limited imaging system with a circular aperture and F -number $F_{\#}$ under (a) coherent and (b) incoherent illumination.

C. Gain of Spatial Coherence by Propagation

Equation (10.3-5) describes the change of the mutual intensity when the light propagates through an optical system of impulse-response function $h(\mathbf{r}; \mathbf{r}')$. When the input light is incoherent, the mutual intensity $G_1(\mathbf{r}_1, \mathbf{r}_2)$ may be replaced by $\sigma[I_1(\mathbf{r}_1)I_1(\mathbf{r}_2)]^{1/2}\delta(\mathbf{r}_1 - \mathbf{r}_2)$ and substituted in the double integral in (10.3-5) to obtain the single integral,

$$G_2(\mathbf{r}_1, \mathbf{r}_2) = \sigma \int h^*(\mathbf{r}_1; \mathbf{r})h(\mathbf{r}_2; \mathbf{r})I_1(\mathbf{r}) d\mathbf{r}. \tag{10.3-19}$$

Image
Mutual Intensity

It is evident that the received light is no longer incoherent. In general, *light gains spatial coherence by the mere act of propagation*. This is not surprising. Although light fluctuations at different points of the input plane are uncorrelated, the radiation from each point spreads and overlaps with that from the neighboring points. The light reaching two points in the output plane comes from many points of the input plane, some of which are common (see Fig. 10.3-6). These common contributions create partial correlation between fluctuations at the output points.

This is not unlike the transmission of an uncorrelated time signal (white noise) through a low-pass filter. The filter smooths the function and reduces its spectral bandwidth, so that its coherence time increases and it is no longer uncorrelated. The propagation of light through an optical system is a form of spatial filtering that cuts the spatial bandwidth and therefore increases the coherence area.

Van Cittert – Zernike Theorem

There is a mathematical similarity between the gain of coherence of initially *incoherent* light propagating through an optical system, and the change of the amplitude of

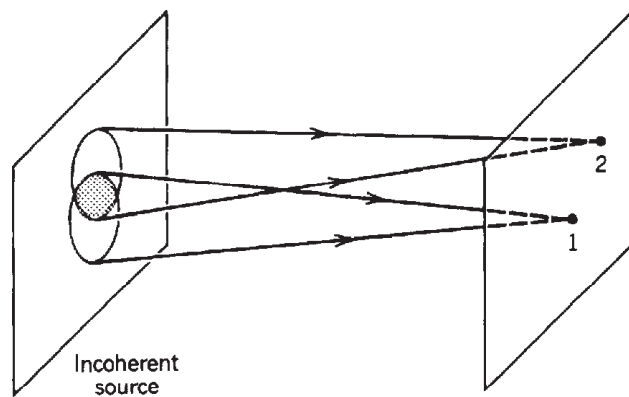

Figure 10.3-6 Gain of coherence by propagation is a result of the spreading of light. Although the light is completely uncorrelated at the source, the light fluctuations at points 1 and 2 share a common origin, the shaded area, and are therefore partially correlated.

coherent light traveling through the same system. In reference to (10.3-19), if the observation point \mathbf{r}_1 is fixed, for example at the origin $\mathbf{0}$, and the mutual intensity $G_2(\mathbf{0}, \mathbf{r}_2)$ is examined as a function of \mathbf{r}_2 , then

$$G_2(\mathbf{0}, \mathbf{r}_2) = \sigma \int h^*(\mathbf{0}; \mathbf{r}) h(\mathbf{r}_2; \mathbf{r}) I_1(\mathbf{r}) d\mathbf{r}. \quad (10.3-20)$$

Defining $U_2(\mathbf{r}_2) = G_2(\mathbf{0}, \mathbf{r}_2)$ and $U_1(\mathbf{r}) = \sigma h^*(\mathbf{0}; \mathbf{r}) I_1(\mathbf{r})$, (10.3-20) may be written in the familiar form

$$U_2(\mathbf{r}_2) = \int h(\mathbf{r}_2; \mathbf{r}) U_1(\mathbf{r}) d\mathbf{r}, \quad (10.3-21)$$

which is exactly the integral (10.3-4) that governs the propagation of coherent light. Thus the observed mutual intensity $G(\mathbf{0}, \mathbf{r}_2)$ at the output of an optical system whose input is incoherent is mathematically identical to the observed complex amplitude if a coherent wave of complex amplitude $U_1(\mathbf{r}) = \sigma h^*(\mathbf{0}; \mathbf{r}) I_1(\mathbf{r})$ were the input to the same system.

As an example, suppose that the incoherent input wave has uniform intensity and extends over an aperture $p(\mathbf{r})$ [$p(\mathbf{r}) = 1$ within the aperture, and zero elsewhere], i.e., $I_1(\mathbf{r}) = p(\mathbf{r})$; and assume that the optical system is free space, i.e., $h(\mathbf{r}'; \mathbf{r}) = \exp(-jk|\mathbf{r}' - \mathbf{r}|)/|\mathbf{r}' - \mathbf{r}|$. The mutual intensity $G_2(\mathbf{0}, \mathbf{r}_2)$ is then identical to the amplitude $U_2(\mathbf{r}_2)$ obtained when a coherent wave with input amplitude $U_1(\mathbf{r}) = \sigma h^*(\mathbf{0}; \mathbf{r}) p(\mathbf{r}) = \sigma p(\mathbf{r}) \exp(jkr)/r$ is transmitted through the same system. This is a spherical wave converging to the point $\mathbf{0}$ in the output plane and transmitted through the aperture.

This similarity between the diffraction of coherent light and the gain of spatial coherence of incoherent light traveling through the same system is known as the **Van Cittert-Zernike theorem**.

Gain of Coherence in Free Space

Consider the optical system of free-space propagation between two parallel planes separated by a distance d (Fig. 10.3-7). Light in the input plane is quasi-monochromatic, spatially incoherent, and has intensity $I(x, y)$ extending over a finite area. The distance d is sufficiently large so that for points of interest in the output plane the Fraunhofer approximation is valid. Under these conditions the impulse-response func-

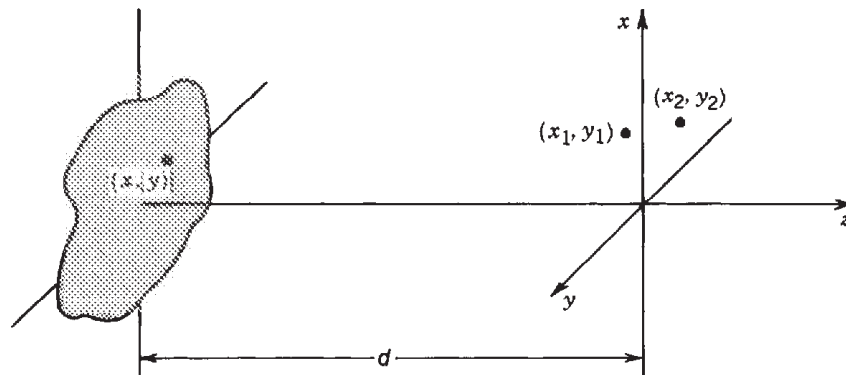

Figure 10.3-7 Radiation from an incoherent source in free space.

tion of the optical system is described by the Fraunhofer diffraction formula [see (4.2-3)]

$$h(\mathbf{r}; \mathbf{r}') = h_0 \exp\left(-j\pi \frac{x^2 + y^2}{\lambda d}\right) \exp\left(j2\pi \frac{xx' + yy'}{\lambda d}\right), \quad (10.3-22)$$

where $\mathbf{r} = (x, y, d)$ and $\mathbf{r}' = (x', y', 0)$ are the coordinates of points in the output and input planes, respectively, and $h_0 = (j/\lambda d) \exp(-j2\pi d/\lambda)$ is a constant.

To determine the mutual coherence function $G(x_1, y_1, x_2, y_2)$ at two points (x_1, y_1) and (x_2, y_2) in the output plane, we substitute (10.3-22) into (10.3-19) and obtain

$$|G(x_1, y_1, x_2, y_2)| = \sigma_1 \left| \iint_{-\infty}^{\infty} \exp\left\{j \frac{2\pi}{\lambda d} [(x_2 - x_1)x + (y_2 - y_1)y]\right\} I(x, y) dx dy \right|, \quad (10.3-23)$$

where $\sigma_1 = \sigma |h_0|^2 = \sigma/\lambda^2 d^2$ is another constant. Given $I(x, y)$, one can easily determine $|G(x_1, y_1, x_2, y_2)|$ in terms of the two-dimensional Fourier transform of $I(x, y)$,

$$\mathcal{F}(\nu_x, \nu_y) = \int_{-\infty}^{\infty} \int_{-\infty}^{\infty} \exp[j2\pi(\nu_x x + \nu_y y)] I(x, y) dx dy \quad (10.3-24)$$

evaluated at $\nu_x = (x_2 - x_1)/\lambda d$ and $\nu_y = (y_2 - y_1)/\lambda d$. The magnitude of the corresponding normalized mutual intensity is

$$|g(x_1, y_1, x_2, y_2)| = \left| \mathcal{F}\left(\frac{x_2 - x_1}{\lambda d}, \frac{y_2 - y_1}{\lambda d}\right) \right| / \mathcal{F}(0, 0). \quad (10.3-25)$$

This Fourier transform relation between the intensity profile of an incoherent source and the degree of spatial coherence of its far field is similar to the Fourier transform relation between the amplitude of coherent light at the input and output planes (see Sec. 4.2A). The similarity is expected in view of the Van Cittert–Zernike theorem.

The implications of (10.3-25) are profound. If the area of the source, i.e., the spatial extent of $I(x, y)$, is small, its Fourier transform $\mathcal{F}(\nu_x, \nu_y)$ is wide, so that the mutual intensity in the output plane extends over a wide area and the area of coherence in the output plane is large. In the extreme limit in which light in the input plane originates

from a point, the area of coherence is infinite and the radiated field is spatially completely coherent. This confirms our earlier discussions in Sec. 10.1D regarding the coherence of spherical waves. On the other hand, if the input incoherent light originates from a large extended source, the propagated light has a small area of coherence.

EXAMPLE 10.3-2. Radiation from an Incoherent Circular Source. For input light with uniform intensity $I(x, y) = I_0$ confined to a circular aperture of radius a , (10.3-25) yields

$$|g(x_1, y_1, x_2, y_2)| = \left| \frac{2J_1(\pi\rho\theta_s/\lambda)}{\pi\rho\theta_s/\lambda} \right|, \tag{10.3-26}$$

where $\rho = [(x_2 - x_1)^2 + (y_2 - y_1)^2]^{1/2}$ is the distance between the two points, $\theta_s = 2a/d$ is the angle subtended by the source, and $J_1(\cdot)$ is the Bessel function. This relation is plotted in Fig. 10.3-8. The Bessel function reaches its first zero when its argument is 3.832. We can therefore define the area of coherence as a circle of radius $\rho_c = 3.832(\lambda/\pi\theta_s)$, so that

$$\rho_c = 1.22 \frac{\lambda}{\theta_s}.$$

$$\tag{10.3-27}$$

Coherence Distance

A similar result, (10.2-14), was obtained using a less rigorous analysis. The area of coherence is inversely proportional to θ_s^2 . An incoherent light source of wavelength $\lambda = 0.6 \mu\text{m}$ and radius 1 cm observed at a distance $d = 100 \text{ m}$, for example, has a coherence distance $\rho_c \approx 3.7 \text{ mm}$.

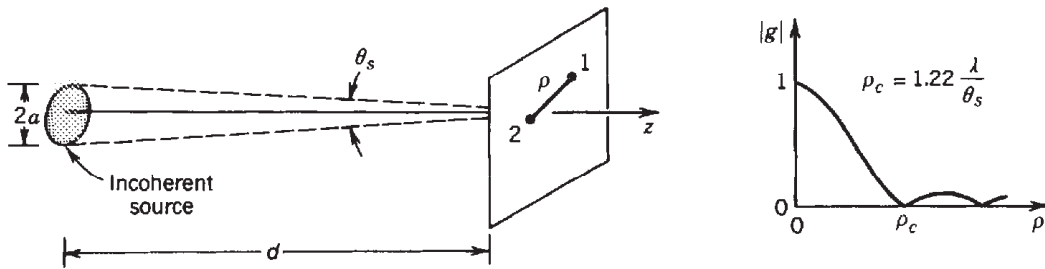

Figure 10.3-8 The magnitude of the degree of spatial coherence of light radiated from an incoherent circular light source subtending an angle θ_s , as a function of the separation ρ .

**Measurement of the Angular Diameter of Stars;
The Michelson Stellar Interferometer**

Equation (10.3-27) is the basis of a method for measuring the angular diameters of stars. If the star is regarded as an incoherent disk of diameter $2a$ with uniform brilliance, then at an observation plane a distance d away from the star, the coherence function drops to 0 when the separation between the two observation points reaches

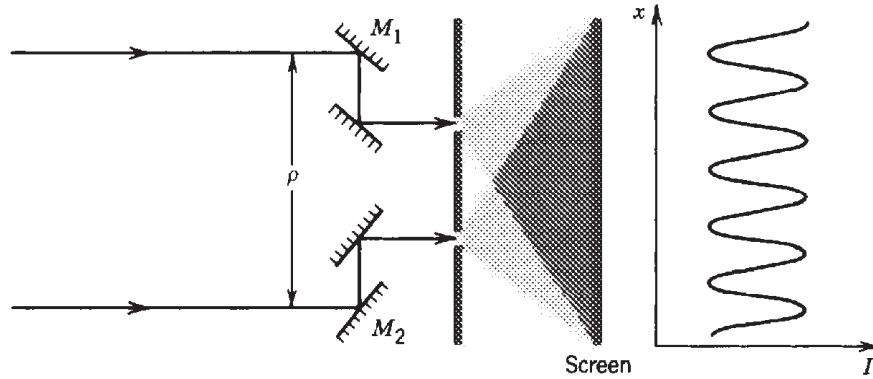

Figure 10.3-9 Michelson stellar interferometer. The angular diameter of a star is estimated by measuring the mutual intensity at two points with variable separation ρ using Young's double-slit interferometer. The distance ρ between mirrors M_1 and M_2 is varied and the visibility of the interference fringes is measured. When $\rho = \rho_c = 1.22\lambda/\theta_s$, the visibility = 0.

$\rho_c = 1.22\lambda/\theta_s$. Measuring ρ_c for a given λ permits us to determine the angular diameter $\theta_s = 2a/d$.

As an example, taking the angular diameter of the sun to be 0.5° , $\theta_s = 8.7 \times 10^{-3}$ radians, and assuming that the intensity is uniform, we obtain $\rho_c \approx 140\lambda$. For $\lambda = 0.5 \mu\text{m}$, $\rho_c = 70 \mu\text{m}$. To observe interference fringes in a Young's double-slit apparatus, the holes would have to be separated by a distance smaller than $70 \mu\text{m}$. Stars of smaller angular diameter have correspondingly larger areas of coherence. For example, the first star whose angular diameter was measured using this technique (α -Orion) has an angular diameter $\theta_s = 22.6 \times 10^{-8}$, so that for $\lambda = 0.57 \mu\text{m}$, $\rho_c = 3.1 \text{ m}$. A Young's interferometer can be modified to accommodate such large slit separations by using movable mirrors, as shown in Fig. 10.3-9.

10.4 PARTIAL POLARIZATION

As we have seen in Chap. 6, the scalar theory of light is often inadequate and a vector theory including the polarization of light is necessary. This section provides a brief discussion of the statistical theory of *random* light, including the effects of polarization. The **theory of partial polarization** is based on characterizing the components of the optical field vector by correlations and cross-correlations similar to those defined earlier in this chapter.

To simplify the presentation, we shall not be concerned with spatial effects. We therefore limit ourselves to light described by a transverse electromagnetic (TEM) plane wave traveling in the z direction. The electric-field vector has two components in the x and y directions with complex wavefunctions $U_x(t)$ and $U_y(t)$ that are generally random. Each function is characterized by its autocorrelation function (the temporal coherence function),

$$G_{xx}(\tau) = \langle U_x^*(t)U_x(t + \tau) \rangle \quad (10.4-1)$$

$$G_{yy}(\tau) = \langle U_y^*(t)U_y(t + \tau) \rangle. \quad (10.4-2)$$

An additional descriptor of the wave is the cross-correlation function of $U_x(t)$ and $U_y(t)$,

$$G_{xy}(\tau) = \langle U_x^*(t)U_y(t + \tau) \rangle. \quad (10.4-3)$$

The normalized function

$$g_{xy}(\tau) = \frac{G_{xy}(\tau)}{[G_{xx}(0)G_{yy}(0)]^{1/2}} \quad (10.4-4)$$

is the cross-correlation coefficient of $U_x^*(t)$ and $U_y(t + \tau)$. It satisfies the inequality $0 \leq |g_{xy}(\tau)| \leq 1$. When the two components are uncorrelated at all times, $|g_{xy}(\tau)| = 0$; and when they are completely correlated at all times, $|g_{xy}(\tau)| = 1$.

The spectral properties are, in general, tied to the polarization properties, so that the autocorrelation and cross-correlation functions have different dependences on τ . However, for quasimonochromatic light all dependences on τ in (10.4-1) to (10.4-4) are approximately of the form $\exp(j2\pi\nu_0\tau)$, so that the polarization properties are described by the values at $\tau = 0$. The three numbers $G_{xx}(0)$, $G_{yy}(0)$, and $G_{xy}(0)$, hereafter denoted G_{xx} , G_{yy} , and G_{xy} , are then used to describe the polarization of the wave. Note that $G_{xx} = I_x$ and $G_{yy} = I_y$ are real numbers that represent the intensities of the x and y components, but G_{xy} is complex and $G_{yx} = G_{xy}^*$, as can easily be verified from the definition.

Coherency Matrix

It is convenient to write the four variables G_{xx} , G_{xy} , G_{yx} , and G_{yy} in the form of a 2×2 Hermitian matrix

$$\mathbf{G} = \begin{bmatrix} G_{xx} & G_{xy} \\ G_{yx} & G_{yy} \end{bmatrix} \quad (10.4-5)$$

called the **coherency matrix**. The diagonal elements are the intensities I_x and I_y , and the off-diagonal elements are the cross-correlations. The trace of the matrix $\text{Tr } \mathbf{G} = I_x + I_y \equiv I$ is the total intensity.

The coherency matrix may also be written in terms of the Jones vector, $\mathbf{J} = \begin{bmatrix} U_x \\ U_y \end{bmatrix}$, defined in terms of the complex wavefunctions and complex amplitudes (instead of in terms of the complex envelopes as in Sec. 6.1),

$$\langle \mathbf{J}^* \mathbf{J}^\dagger \rangle = \left\langle \begin{bmatrix} U_x^* \\ U_y^* \end{bmatrix} \begin{bmatrix} U_x & U_y \end{bmatrix} \right\rangle = \begin{bmatrix} \langle U_x^* U_x \rangle & \langle U_x^* U_y \rangle \\ \langle U_y^* U_x \rangle & \langle U_y^* U_y \rangle \end{bmatrix} = \mathbf{G}, \quad (10.4-6)$$

where \dagger denotes the transpose of a matrix, and U_x and U_y denote $U_x(t)$ and $U_y(t)$, respectively.

The Jones vector is transformed by polarization devices, such as polarizers and retarders, in accordance with the rule $\mathbf{J}' = \mathbf{T}\mathbf{J}$ [see (6.1-10)], where \mathbf{T} is the Jones matrix representing the device [see (6.1-11) to (6.1-18)]. The coherency matrix is therefore transformed in accordance with $\mathbf{G}' = \langle \mathbf{T}^* \mathbf{J}^* (\mathbf{T}\mathbf{J})^\dagger \rangle = \langle \mathbf{T}^* \mathbf{J}^* \mathbf{J}^\dagger \mathbf{T}^\dagger \rangle = \mathbf{T}^* \langle \mathbf{J}^* \mathbf{J}^\dagger \rangle \mathbf{T}^\dagger$, so that

$$\boxed{\mathbf{G}' = \mathbf{T}^* \mathbf{G} \mathbf{T}^\dagger} \quad (10.4-7)$$

We thus have a formalism for determining the effect of polarization devices on the coherency matrix of partially polarized light.

To understand the significance of the coherency matrix, we examine next two limiting cases.

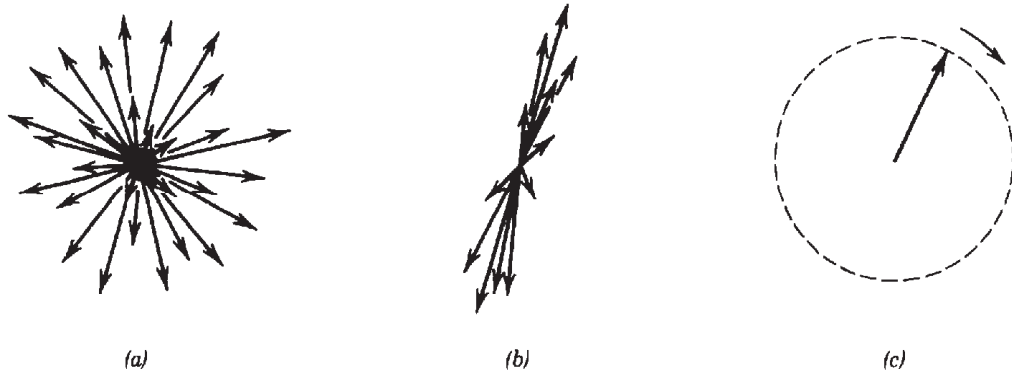

Figure 10.4-1 Fluctuations of the electric field vector for (a) unpolarized light; (b) partially polarized light; (c) polarized light with circular polarization.

Unpolarized Light

Light of intensity \bar{I} is said to be **unpolarized** if its two components have the same intensity and are uncorrelated, $I_x = I_y \equiv \frac{1}{2}\bar{I}$ and $G_{xy} = 0$. The coherency matrix is then

$$\mathbf{G} = \frac{1}{2}\bar{I} \begin{bmatrix} 1 & 0 \\ 0 & 1 \end{bmatrix}. \quad (10.4-8)$$

By use of (10.4-7) and (6.1-15), it can be shown that (10.4-8) is invariant to rotation of the coordinate system, so that the two components always have equal intensities and are uncorrelated. Unpolarized light therefore has an electric field vector that is statistically isotropic; it is equally likely to have any direction in the x - y plane, as illustrated in Fig. 10.4-1(a).

When passed through a polarizer, unpolarized light becomes linearly polarized, but it remains random with an average intensity $\frac{1}{2}\bar{I}$. A wave retarder has no effect on unpolarized light since it only introduces a phase shift between two components that have a totally random phase to begin with. Similarly, unpolarized light transmitted through a polarization rotator remains unpolarized. These effects may be shown formally by use of (10.4-7) and (10.4-8) together with (6.1-11), (6.1-12), and (6.1-13).

Polarized Light

If the cross-correlation coefficient $g_{xy} = G_{xy}/[I_x I_y]^{1/2}$ has unit magnitude, $|g_{xy}| = 1$, the two components of the optical field are perfectly correlated and the light is said to be completely polarized (or simply **polarized**). Since $g_{xy} = G_{xy}/[I_x I_y]^{1/2}$, the coherency matrix takes the form

$$\mathbf{G} = \begin{bmatrix} I_x & (I_x I_y)^{1/2} e^{j\varphi} \\ (I_x I_y)^{1/2} e^{-j\varphi} & I_y \end{bmatrix}, \quad (10.4-9)$$

where φ is the argument of g_{xy} . Defining $U_x = I_x^{1/2}$ and $U_y = I_y^{1/2} e^{j\varphi}$,

$$\mathbf{G} = \begin{bmatrix} U_x^* U_x & U_x^* U_y \\ U_y^* U_x & U_y^* U_y \end{bmatrix} = \mathbf{J}^* \mathbf{J}^\dagger, \quad (10.4-10)$$

where \mathbf{J} is a Jones matrix with components U_x and U_y . Thus \mathbf{G} has the same form as the coherency matrix of a coherent wave.

Using the Jones vectors listed in Table 6.1-1 on page 198, we can determine the coherency matrices for different states of polarization. Two examples are:

Linearly polarized in the x direction	$\mathbf{G} = \bar{I} \begin{bmatrix} 1 & 0 \\ 0 & 0 \end{bmatrix}$	Right-circularly polarized	$\mathbf{G} = \frac{1}{2} \bar{I} \begin{bmatrix} 1 & j \\ -j & 1 \end{bmatrix}$
--	---	-------------------------------	--

It is instructive to examine the distinction between unpolarized light and circularly polarized light. In both cases the intensities of the x and y components are equal ($I_x = I_y$). For circularly polarized light the two components are completely correlated, but for unpolarized light they are uncorrelated. Circularly polarized light may be transformed into linearly polarized light by the use of a wave retarder, but unpolarized light remains unpolarized upon passage through such a device.

Degree of Polarization

Partial polarization is a general state of random polarization that lies between the two ideal limits of unpolarized and polarized light. One measure of the **degree of polarization** is defined in terms of the determinant and the trace of the coherency matrix:

$$\mathcal{P} = \left\{ 1 - \frac{4 \det \mathbf{G}}{(\text{Tr } \mathbf{G})^2} \right\}^{1/2} \quad (10.4-11)$$

$$= \left\{ 1 - 4 \left[\frac{I_x I_y}{(I_x + I_y)^2} \right] (1 - |g_{xy}|^2) \right\}^{1/2} \quad (10.4-12)$$

This measure is meaningful because of the following considerations:

- It satisfies the inequality $0 \leq \mathcal{P} \leq 1$.
- For polarized light, \mathcal{P} has its highest value of 1, as can easily be seen by substituting $|g_{xy}| = 1$ into (10.4-12). For unpolarized light it has its lowest value $\mathcal{P} = 0$, since $I_x = I_y$ and $g_{xy} = 0$.
- It is invariant to rotation of the coordinate system (since the determinant and the trace of a matrix are invariants to unitary transformations).
- It can be shown (Exercise 10.4-1) that a partially polarized wave can always be regarded as a mixture of two uncorrelated waves: a completely polarized wave and an unpolarized wave, with the ratio of the intensity of the polarized component to the total intensity equal to the degree of polarization \mathcal{P} .

EXERCISE 10.4-1

Partially Polarized Light. Show that the superposition of unpolarized light of intensity $(I_x + I_y)(1 - \mathcal{P})$, and linearly polarized light with intensity $(I_x + I_y)\mathcal{P}$, where \mathcal{P} is given by (10.4-12), yields light whose x and y components have intensities I_x and I_y and normalized cross-correlation $|g_{xy}|$.

READING LIST

General

- G. Reynolds, J. B. DeVelis, G. Parrent, and B. J. Thompson, *The New Physical Optics Notebook: Tutorials in Fourier Optics*, SPIE—The International Society for Optical Engineering, Bellingham, WA, and American Institute of Physics, New York, 1989.
- J. W. Goodman, *Statistical Optics*, Wiley, New York, 1985.
- J. Peřina, *Coherence of Light*, Van Nostrand-Reinhold, London, 1971, 2nd ed. 1985.
- B. R. Frieden, *Probability, Statistical Optics, and Data Testing*, Springer-Verlag, Berlin, 1983.
- A. S. Marathay, *Elements of Optical Coherence Theory*, Wiley, New York, 1982.
- M. Born and E. Wolf, *Principles of Optics*, Pergamon Press, New York, 1959, 6th ed. 1980, Chap. 10.
- B. Saleh, *Photoelectron Statistics with Applications to Spectroscopy and Optical Communication*, Springer-Verlag, Berlin, 1978.
- B. Crosignani, P. Di Porto, and M. Bertolotti, *Statistical Properties of Scattered Light*, Academic Press, New York, 1975.
- J. C. Dainty, ed., *Laser Speckle and Related Phenomena*, Springer-Verlag, Berlin, 1975.
- R. Hanbury-Brown, *The Intensity Interferometer*, Taylor and Francis, London, 1974.
- G. J. Troup, *Optical Coherence Theory*, Methuen, London, 1967.
- M. J. Beran and G. B. Parrent, Jr., *Theory of Partial Coherence*, Prentice-Hall, Englewood Cliffs, NJ, 1964.
- E. L. O'Neil, *Introduction to Statistical Optics*, Addison-Wesley, Reading, MA, 1963.

Books on Random Functions

- C. W. Helstrom, *Probability and Stochastic Processes for Engineers and Scientists*, Macmillan, New York, 2nd ed. 1991.
- A. Papoulis, *Probability, Random Variables, and Stochastic Processes*, McGraw-Hill, New York, 1965, 2nd ed. 1984.
- E. Vanmarcke, *Random Fields*, MIT Press, Cambridge, MA, 1983.
- E. Parzen, *Modern Probability Theory and Its Applications*, Wiley, New York, 1960.

Articles

- Journal of the Optical Society of America*, Feature issues on applications of coherence and statistical optics, no. 7, 1986 and no. 8, 1986.
- F. T. S. Yu, Principles of Optical Processing with Partially Coherent Light, in *Progress in Optics*, vol. 23, E. Wolf, ed., North-Holland, Amsterdam, 1986.
- W. J. Tango and R. Q. Twiss, Michelson Stellar Interferometry, in *Progress in Optics*, vol. 17, E. Wolf, ed., North-Holland, Amsterdam, 1980.
- G. O. Reynolds and J. B. DeVelis, Review of Optical Coherence Effects in Instrument Design, *SPIE Proceedings*, vol. 194, p. 2, 1979.
- E. Wolf, Coherence and Radiometry, *Journal of the Optical Society of America*, vol. 68, pp. 6–17, 1978.
- H. P. Baltes, J. Geist, and A. Walther, Radiometry and Coherence, in *Inverse Source Problems in Optics*, H. P. Baltes, ed., Springer-Verlag, New York, 1978.
- L. Mandel and E. Wolf, eds., *Selected Papers on Coherence and Fluctuations of Light*, vols. 1 and 2, Dover, New York, 1970.
- B. J. Thompson, Image Formation with Partially Coherent Light, in *Progress in Optics*, vol. 7, E. Wolf, ed., North-Holland, Amsterdam, 1969.
- L. Mandel and E. Wolf, Coherence Properties of Optical Fields, *Reviews of Modern Physics*, vol. 37, pp. 231–287, 1965.

PROBLEMS

- 10.1-1 **Lorentzian Spectrum.** A light-emitting diode (LED) emits light of Lorentzian spectrum with a linewidth $\Delta\nu$ (FWHM) = 10^{13} Hz centered about a frequency corresponding to a wavelength $\lambda_o = 0.7 \mu\text{m}$. Determine the linewidth $\Delta\lambda_o$ (in units of nm), the coherence time τ_c , and the coherence length l_c . What is the maximum time delay within which the magnitude of the complex degree of temporal coherence $|g(\tau)|$ is greater than 0.5?
- 10.1-2 **Proof of the Wiener–Khinchin Theorem.** Use the definitions in (10.1-4), (10.1-11), and (10.1-12) to prove that the spectral density $S(\nu)$ is the Fourier transform of the autocorrelation function $G(\tau)$. Prove that the intensity I is the integral of the power spectral density $S(\nu)$.
- 10.1-3 **Mutual Intensity.** The mutual intensity of an optical wave at points on the x axis is given by

$$G(x_1, x_2) = I_0 \exp\left[-\frac{(x_1^2 + x_2^2)}{W_0^2}\right] \exp\left[-\frac{(x_1 - x_2)^2}{\rho_c^2}\right],$$

where I_0 , W_0 , and ρ_c are constants. Sketch the intensity distribution as a function of x . Derive an expression for the normalized mutual intensity $g(x_1, x_2)$ and sketch it as a function of $x_1 - x_2$. What is the physical meaning of the parameters I_0 , W_0 , and ρ_c ?

- 10.1-4 **Mutual Coherence Function.** An optical wave has a mutual coherence function at points on the x axis,

$$G(x_1, x_2, \tau) = \exp\left(-\frac{\pi\tau^2}{2\tau_c^2}\right) \exp[j2\pi u(x_1, x_2)\tau] \exp\left[-\frac{(x_1 - x_2)^2}{\rho_c^2}\right],$$

where $u(x_1, x_2) = 5 \times 10^{14} \text{ s}^{-1}$ for $x_1 + x_2 > 0$, and $6 \times 10^{14} \text{ s}^{-1}$ for $x_1 + x_2 < 0$, $\rho_c = 1 \text{ mm}$, and $\tau_c = 1 \mu\text{s}$. Determine the intensity, the power spectral density, the coherence length, and the coherence distance in the transverse plane. Which of these quantities is position dependent? If this wave is recorded on color film, what would the recorded image look like?

- 10.1-5 **Coherence Length.** Show that light of narrow spectral width has a coherence length $l_c \approx \lambda^2/\Delta\lambda$, where $\Delta\lambda$ is the linewidth in wavelength units. Show that for light of broad uniform spectrum extending between the wavelengths λ_{\min} and $\lambda_{\max} = 2\lambda_{\min}$, the coherence length $l_c = \lambda_{\max}$.
- 10.1-6 **Effect of Spectral Width on Spatial Coherence.** A point source at the origin $(0, 0, 0)$ of a Cartesian coordinate system emits light with a Lorentzian spectrum and coherence time $\tau_c = 10 \text{ ps}$. Determine an expression for the normalized mutual intensity of the light at the points $(0, 0, d)$ and $(x, 0, d)$, where $d = 10 \text{ cm}$. Sketch the magnitude of the normalized mutual intensity as a function of x .
- 10.1-7 **Gaussian Mutual Intensity.** An optical wave in free space has a mutual coherence function $G(\mathbf{r}_1, \mathbf{r}_2, \tau) = J(\mathbf{r}_1 - \mathbf{r}_2) \exp(j2\pi\nu_0\tau)$. (a) Show that the function $J(\mathbf{r})$ must satisfy the Helmholtz equation $\nabla^2 J + k_o^2 J = 0$, where $k_o = 2\pi\nu_0/c$. (b) An

approximate solution of the Helmholtz equation is the Gaussian-beam solution

$$J(\mathbf{r}) = \frac{1}{q(z)} \exp \left[-\frac{jk_o(x^2 + y^2)}{2q(z)} \right] \exp(-jk_o z),$$

where $q(z) = z + jz_0$ and z_0 is a constant. This solution has been studied extensively in Chap. 3 in connection with Gaussian beams. Determine an expression for the coherence area near the z axis and show that it increases with $|z|$, so that the wave gains coherence with propagation away from the origin.

- 10.2-1 **Effect of Spectral Width on Fringe Visibility.** Light from a sodium lamp of Lorentzian spectral linewidth $\Delta\nu = 5 \times 10^{11}$ Hz is used in a Michelson interferometer. Determine the maximum path-length difference for which the visibility of the interferogram $\mathcal{V} > \frac{1}{2}$.
- 10.2-2 **Number of Observable Fringes in Young's Interferometer.** Determine the number of observable fringes in Young's interferometer if each of the sources in Table 10.1-2 on page 352 is used. Assume full spatial coherence in all cases.
- 10.2-3 **Spectrum of a Superposition of Two Waves.** An optical wave is a superposition of two waves $U_1(t)$ and $U_2(t)$ with identical spectra $S_1(\nu) = S_2(\nu)$, which are Gaussian with spectral width $\Delta\nu$ and central frequency ν_0 . The waves are not necessarily uncorrelated. Determine an expression for the power spectral density $S(\nu)$ of the superposition $U(t) = U_1(t) + U_2(t)$. Explore the possibility that $S(\nu)$ is also Gaussian, with a shifted central frequency $\nu_1 \neq \nu_0$. If this were possible, our faith in using the Doppler shift as a method to determine the velocity of stars would be shaken, since frequency shifts could originate from something other than the Doppler effect.
- *10.3-1 **Partially Coherent Gaussian Beam.** A quasi-monochromatic light wave of wavelength λ travels in free space in the z direction. Its intensity in the $z = 0$ plane is a Gaussian function $I(x) = I_0 \exp(-2x^2/W_0^2)$ and its normalized mutual intensity is also a Gaussian function $g(x_1, x_2) = \exp[-(x_1 - x_2)^2/\rho_c^2]$. Show that the intensity at a distance z satisfying conditions of the Fraunhofer approximation is also a Gaussian function $I_z(x) \propto \exp[-2x^2/W^2(z)]$ and derive an expression for the beam radius $W(z)$ as a function of z and the parameters W_0 , ρ_c , and λ . Discuss the effect of spatial coherence on beam divergence.
- *10.3-2 **Fourier-Transform Lens.** Quasi-monochromatic spatially incoherent light of uniform intensity illuminates a transparency of intensity transmittance $f(x, y)$ and the emerging light is transmitted between the front and back focal planes of a lens. Determine an expression for the intensity of the observed light. Compare your results with the case of coherent light in which the lens performs the Fourier transform (see Sec. 4.2).
- *10.3-3 **Light from a Two-Point Incoherent Source.** A spatially incoherent quasi-monochromatic source of light emits only at two points separated by a distance $2a$. Determine an expression for the normalized mutual intensity at a distance d from the source (use the Fraunhofer approximation).
- *10.3-4 **Coherence of Light Transmitted Through a Fourier-Transform Optical System.** Light from a quasi-monochromatic spatially incoherent source with uniform intensity is transmitted through a thin slit of width $2a$ and travels between the front and back focal planes of a lens. Determine an expression for the normalized mutual intensity in the back focal plane.

- 10.4-1 **Partially Polarized Light.** The intensities of the two components of a partially polarized wave are $I_x = I_y = \frac{1}{2}$, and the argument of the cross-correlation coefficient g_{xy} is $\pi/2$.
- Plot the degree of polarization \mathcal{P} versus the magnitude of the cross-correlation coefficient $|g_{xy}|$.
 - Determine the coherency matrix if $\mathcal{P} = 0, 0.5$, and 1, and describe the nature of the light in each case.
 - If the light is transmitted through a polarizer with its axis in the x direction, what is the intensity of the light transmitted?